



by Schneider Electric

Job Name: JHU/APL SUBS 2 & 3 CONSOLIDATION
Job Location: LAUREL, MD

Square D Quotation #: 27452521
Quotation Revision #:
Sales Contact: rowan
Sales Contact Location: 150

Purchaser: HAGEMEYER NORTH AMERICA INC
Purchaser PO #: J11054241CC

Customer: ELECTRICO INC
Customer PO #:

User: JOHNS HOPKINS UNIVERSITY
User Location:

Architect: CENTURY ENGINEERING INC
Cons. Engineer:

Drawing Status: RECORD

TABLE OF CONTENTS

SQUARE D FACTORY ORDER NUMBER: 27452521-006

Table with 6 columns: Equipment Designation, Equipment Type, Drawing Type, Drawing Number, Page, Revision Level. Lists various drawings for SUBSTATION A, including SWITCHGEAR RATING NAMEPLATE, AUTO-TRANSFER SCHEME ELEVATION, TOP VIEW/FLOOR PLAN, SIDE VIEW, GENERAL NOTES, DOOR DETAIL, ONE LINE, DEVICE TABLE, KEY INTERLOCK SCHEME, ELEMENTARY DIAGRAM, and WIRING DIAGRAM.

February 09, 2010

Page 1 of 2

Rev: B

TABLE OF CONTENTS

SQUARE D FACTORY ORDER NUMBER: 27452521-006

<u>Equipment Designation</u>	<u>Equipment Type</u>	<u>Drawing Type</u>	<u>Drawing Number</u>	<u>Page</u>	<u>Revision Level</u>
			W27452521-006-01	3	-
			W27452521-006-02	1	-
			W27452521-006-02	2	-
			W27452521-006-03	1	-
			W27452521-006-03	2	-
			W27452521-006-03	3	-
			W27452521-006-04	1	-
			W27452521-006-04	2	-
			W27452521-006-04	3	-
			W27452521-006-04	4	-
			W27452521-006-04	5	-
			W27452521-006-04	6	-
			W27452521-006-05	1	-
			W27452521-006-05	2	-
			W27452521-006-05	3	-
			W27452521-006-06	1	-
			W27452521-006-06	2	-
			W27452521-006-07	1	-
			W27452521-006-07	2	-
			W27452521-006-07	3	-
			W27452521-006-07	4	-
			W27452521-006-WI	1	-
			W27452521-006-WI	2	-
			W27452521-006-WI	3	-
			W27452521-006-WI	4	-
			W27452521-006-WI	5	-
			W27452521-006-WI	6	-
			W27452521-006-WI	7	-
			I27452521-006-01	1	-
		ISOMETRIC VIEW/ COMPARTMENT DESIGNATION COMMUNICATIONS ONE-LINE DIAGRAM	I27452521-006-02	1	-
		GROUNDFAULT TOPOLOGY	I27452521-006-03	1	-
		MIMIC BUS	N27452521-006-01	1	-
		NAMEPLATE	N27452521-006-01	2	-

REV	DESCRIPTION	BY	DATE						
-	-	-	-	-	-	-	-	-	-

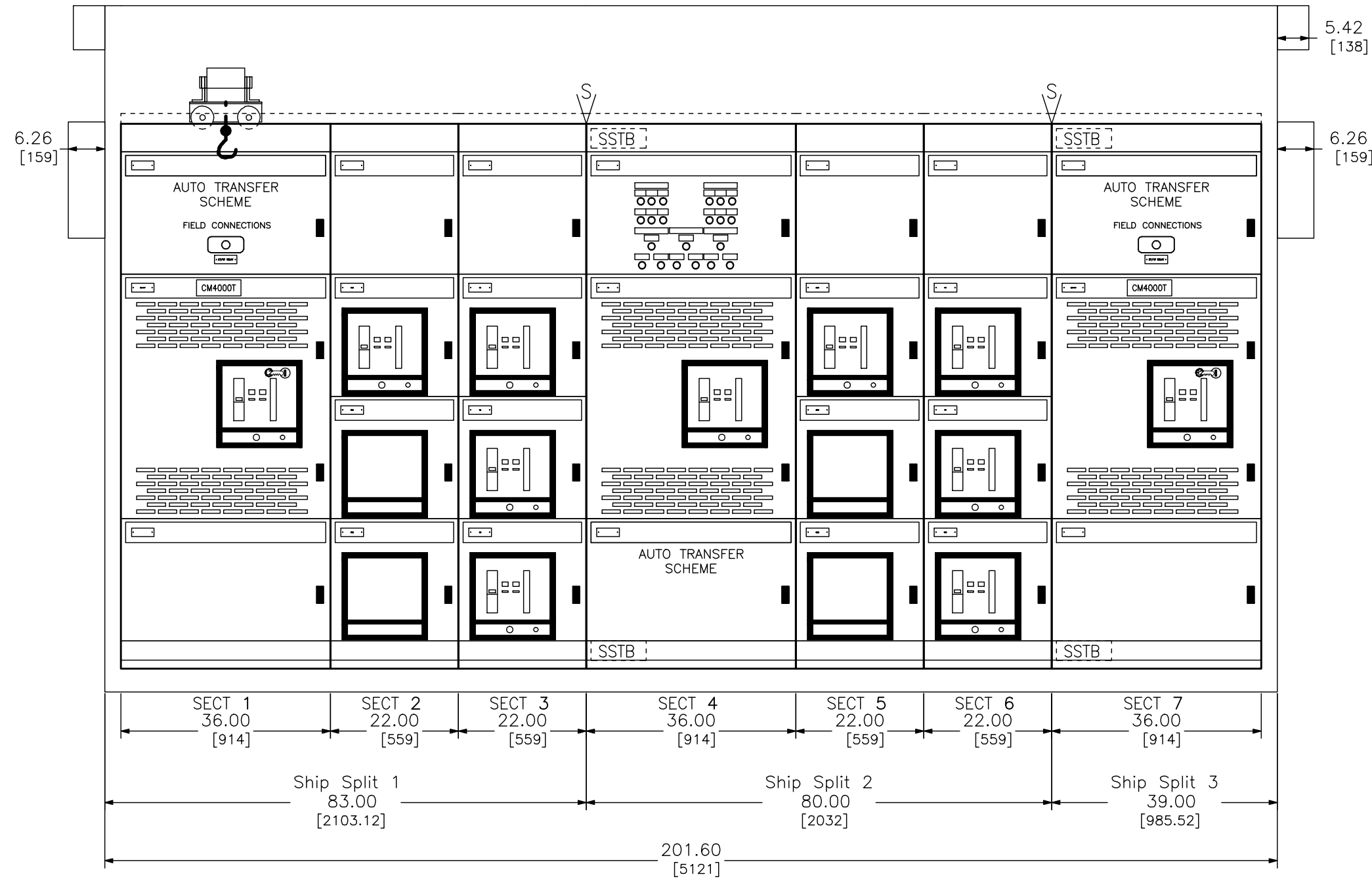

DUAL DIMENSIONS: INCHES
MILLIMETERS

FRONT ELEVATION

JOB NAME:	JHU/APL SUBS 2 & 3 CONSOLIDATION	EQUIPMENT DESIGNATION:	SUBSTATION A
JOB LOCATION:	LAUREL MD	EQUIPMENT TYPE:	PZ4 SWITCHGEAR
DRAWN BY:	S.KUNDU/A.JEER	DRAWING TYPE:	ELEVATION
ENGR:	S.ADONGO		
DATE:	NOVEMBER 11 2009		
DRAWING STATUS:	RECORD	DWG#	F27452521-006-01

REV	DESCRIPTION	BY	DATE						
-	----	--	--/--/--	-	----	--	--/--/--	-	----
-	----	--	--/--/--	-	----	--	--/--/--	-	----

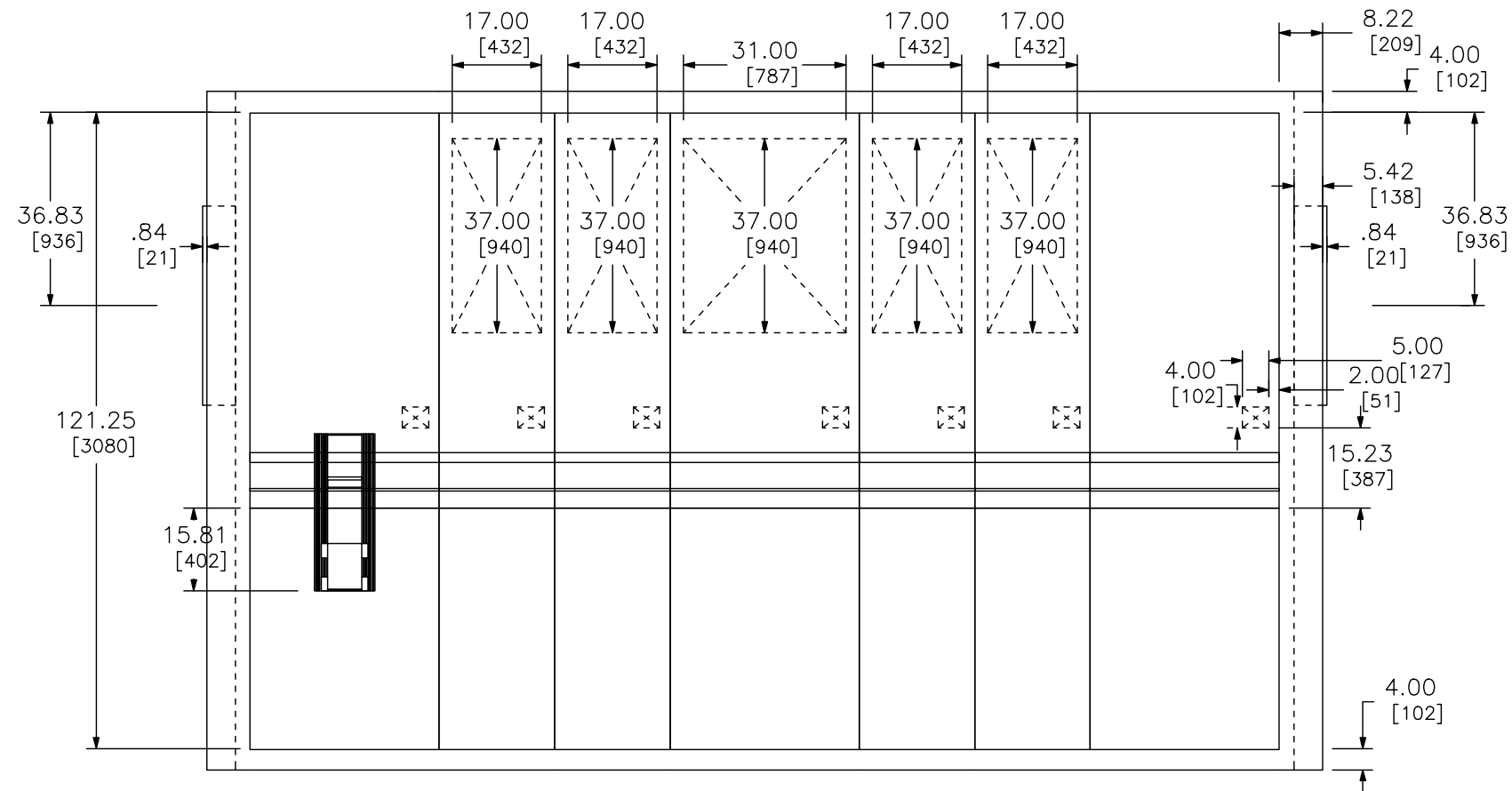

TOP VIEW

JOB NAME:	JHU/APL SUBS 2 & 3 CONSOLIDATION	EQUIPMENT DESIGNATION:	SUBSTATION A
JOB LOCATION:	LAUREL MD	EQUIPMENT TYPE:	PZ4 SWITCHGEAR
DRAWN BY:	S.KUNDU/A.JEER	DRAWING TYPE:	TOP VIEW/FLOOR PLAN
ENGR:	S.ADONGO		
DATE:	NOVEMBER 11 2009	by Schneider Electric	
DRAWING STATUS:	RECORD	DWG#	F27452521-006-01
		PG	2 OF 5
		REV	-

REV	DESCRIPTION	BY	DATE						
-	----	--	---/---/---	-	----	--	---/---/---	-	----

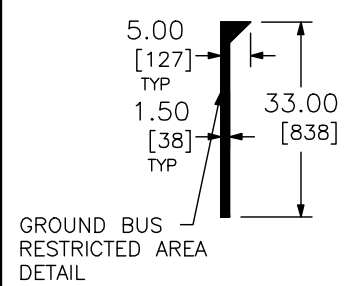
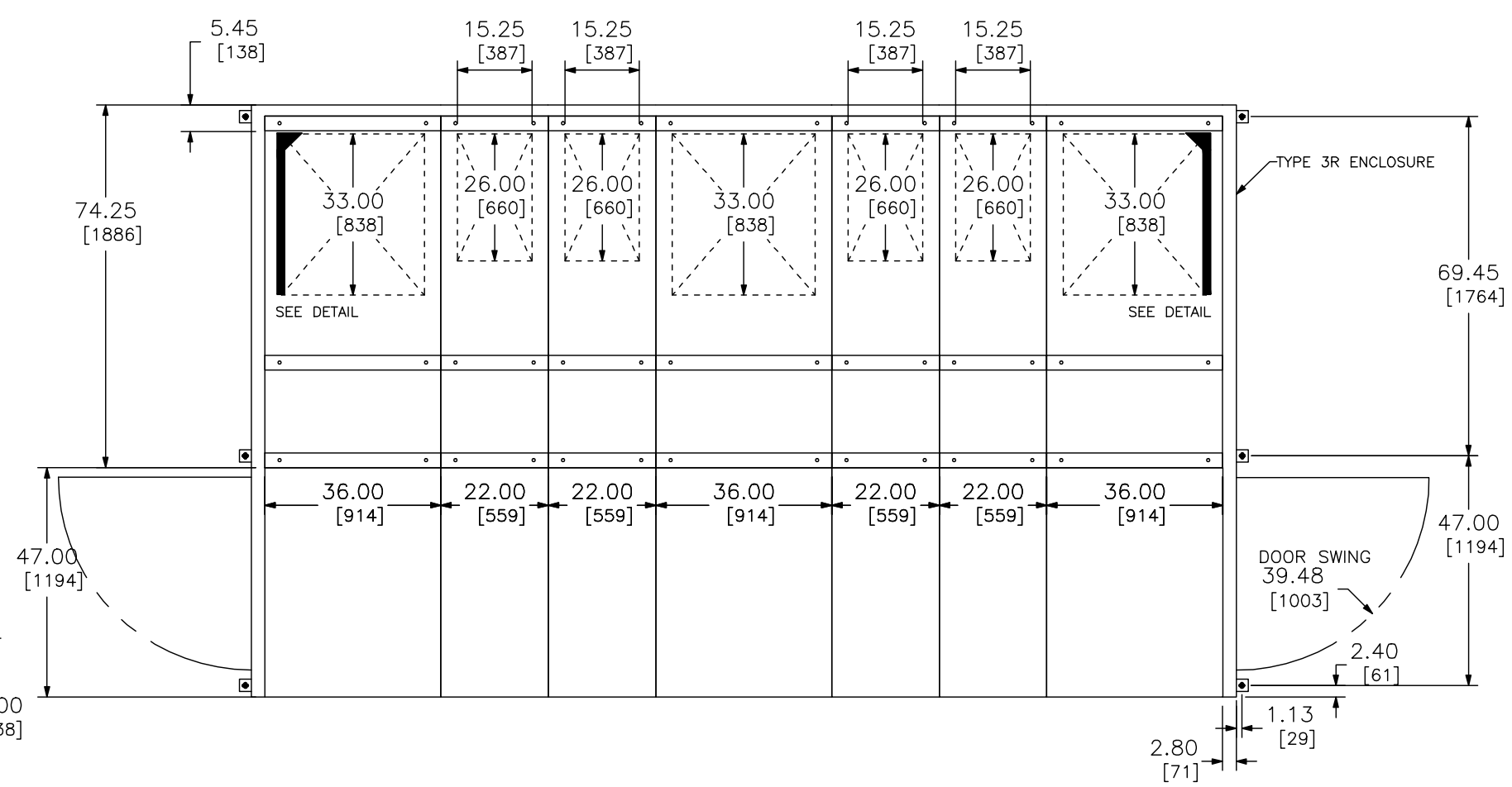

FLOOR PLAN

JOB NAME:	JHU/APL SUBS 2 & 3 CONSOLIDATION	EQUIPMENT DESIGNATION:	SUBSTATION A
JOB LOCATION:	LAUREL MD	EQUIPMENT TYPE:	PZ4 SWITCHGEAR
DRAWN BY:	S.KUNDU/A.JEER	DRAWING TYPE:	TOP VIEW/FLOOR PLAN
ENGR:	S.ADONGO		
DATE:	NOVEMBER 11 2009		
DRAWING STATUS:	RECORD	DWG#	F27452521-006-01

REV	DESCRIPTION	BY	DATE						
-	----	--	---/---/---	-	----	--	---/---/---	-	----

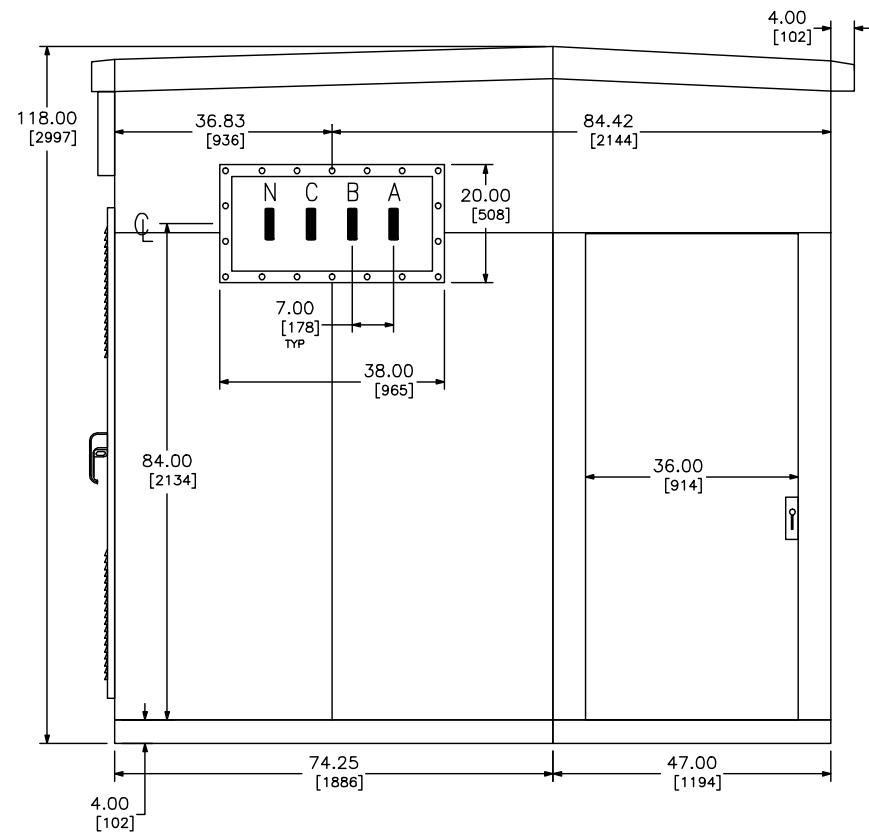

LEFT SIDE VIEW

UNIT SUBSTATION TRANSFORMER INFORMATION

TRANSFORMER TYPE: LIQUID-FILLED
 KVA: 3750 OA/FFA LESS FANS
 TEMP RISE: (DEG C) 65
 % IMPEDANCE: 6.75
 PRIMARY VOLTAGE: 34500 DELTA
 SECONDARY VOLTAGE: 480Y/277
 DRAWING NUMBER: 43502-101-36 REV A

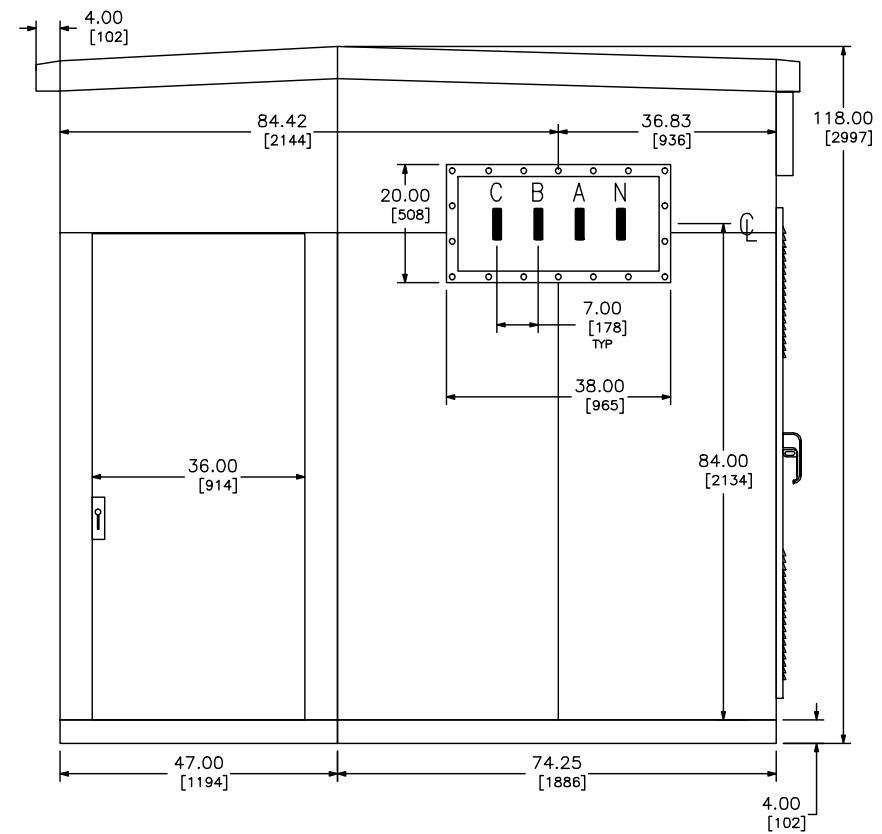

RIGHT SIDE VIEW

UNIT SUBSTATION TRANSFORMER INFORMATION

TRANSFORMER TYPE: LIQUID-FILLED
 KVA: 3750 OA/FFA LESS FANS
 TEMP RISE: (DEG C) 65
 % IMPEDANCE: 6.75
 PRIMARY VOLTAGE: 34500 DELTA
 SECONDARY VOLTAGE: 480Y/277
 DRAWING NUMBER: 43502-101-35 REV A

SIDE VIEWS

JOB NAME:	JHU/APL SUBS 2 & 3 CONSOLIDATION	EQUIPMENT DESIGNATION:	SUBSTATION A
JOB LOCATION:	LAUREL MD	EQUIPMENT TYPE:	PZ4 SWITCHGEAR
DRAWN BY:	S.KUNDU/A.JEER	DRAWING TYPE:	SIDE VIEW
ENGR:	S.ADONGO	 by Schneider Electric	
DATE:	NOVEMBER 11 2009	DWG#	F27452521-006-01
DRAWING STATUS:	RECORD	PG	4 OF 5 REV -

REV	DESCRIPTION	BY	DATE								
-	----	--	---/---/---	-	----	--	---/---/---	-	----	--	---/---/---

GENERAL NOTES

Product Description & Rating

Power System Data

480/277V 3ph-4W, 60 Hz.
Solidly Grounded Neutral
Neutral 100% Of Main Bus Rating
Maximum Available Fault Current (RMS): 85kA
Bus Bracing (RMS): 85kA
Incoming Section Bay 1 Liquid Transformer
Incoming Section Bay 7 Liquid Transformer
Control Power: External 240Vac and 120Vac

Bus System Data

5000A Copper Bus, Silver Flash and Tin Plated, Thermal Rated
Insulated Bus with Boots covering bolted joints

Enclosure Data

Enclosure Type: Outdoor Type 3R Walk-In
Exterior Paint Color: ANSI 49
Bottom Plate/Rodent Proof
Undercoating Applied
Interbay Barriers, Cable Compartment
Rear Barriers between Bus/Cable Compartment
Interbay Barriers, Bus Compartment
Space Heaters- NW Breaker Compartments
Space Heaters- Cable Compartments
Space Heaters- Bus Compartments
Thermostat for Space Heaters
Humidistat for Space Heaters

Estimated Shipping Weight

Ship Split 1 7855.4 LBS / 3570.10 KGS
Ship Split 2 7855.4 LBS / 3570.10 KGS
Ship Split 3 2726.3 LBS / 1239. KGS

Code Standards

Equipment built to ANSI/UL1558 Code Standards
Incoming Section Bay 1 is Suitable for use as Service Entrance w. less than 6 disconnects
Incoming Section Bay 7 is Suitable for use as Service Entrance w. less than 6 disconnects

Product Information

Wiring

Wires shall be labeled with destination marking (point-to-point)
NOTE: When connecting cables, use 90 degree Celsius insulated conductors based on the ampacity of 75 degree Celsius conductors unless otherwise indicated by supplemental instructions.





Instruction Bulletins

Refer to 80298-002-06 Instruction Bulletin for PZ4 installation
Refer to 80298-156-01 Instruction Bulletin for NEMA3R installation

Product Accessories

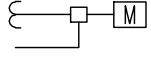
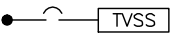
Automatic Transfer System - Standard Main-Tie-Main with Closed Transfer Option
TRE Level 0 Equipment- Network Provisions Only
24VDC Power Supply for Breaker Trip Unit Display and Communications
Section Bay 1 CM4000T Circuit Monitor with ECC Card
Section Bay 7 CM4000T Circuit Monitor
Overhead Breaker Lifter with Rails
Full Breaker Test Kit
Spare Paint (3 cans)
Spare Fuses (6 Sets)
Spare Lights and Lenses (6 Sets)
Certified Test Report
Spare Breaker OF Contacts wired to Terminal Blocks
Fungus Proofing
Painted Mimic Bus
Section Bay 1 27/47 Relay Test Block
Section Bay 7 27/47 Relay Test Block

SYMBOL LEGEND

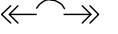
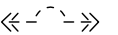
	SURGE ARRESTOR
	POWER METER OR CIRCUIT MONITOR
	SURGE CAPACITOR
	NEUTRAL CONNECTION WITH CT
	NEUTRAL CONNECTION WITHOUT CT
	NEUTRAL DISCONNECT LINK
	CIRCUIT BREAKER
	PREPARED CELL

GENERAL NOTES

JOB NAME:	JHU/APL SUBS 2 & 3 CONSOLIDATION	EQUIPMENT DESIGNATION:	SUBSTATION A
JOB LOCATION:	LAUREL MD	EQUIPMENT TYPE:	PZ4 SWITCHGEAR
DRAWN BY:	S.KUNDU/A.JEER	DRAWING TYPE:	GENERAL NOTES
ENGR:	S.ADONGO		
DATE:	NOVEMBER 11 2009	<small>by Schneider Electric</small>	
DRAWING STATUS:	RECORD	DWG#	F27452521-006-01
			PG 5 OF 5 REV -

REV	DESCRIPTION	BY	DATE						
-	-	-	-	-	-	-	-	-	-

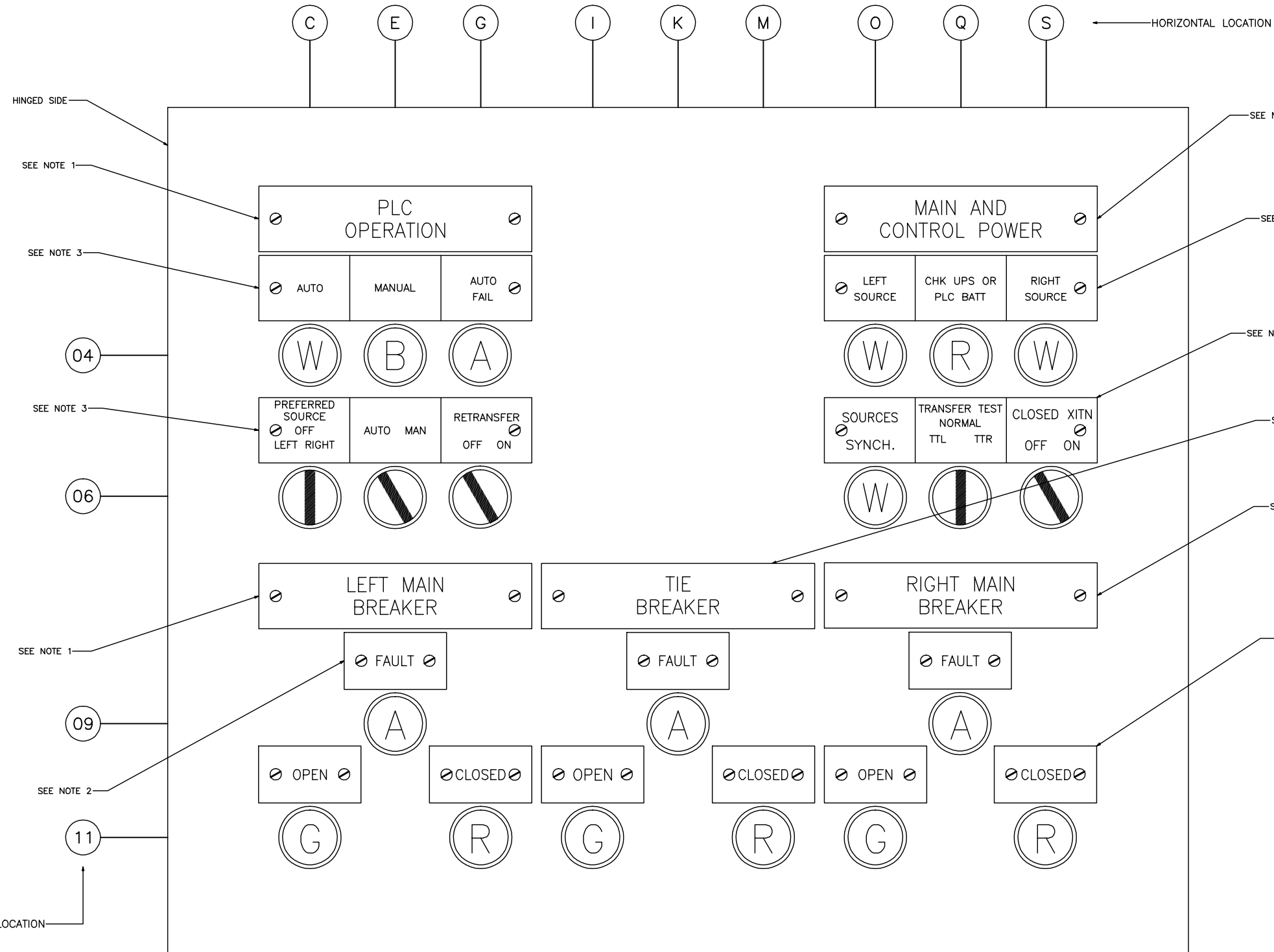

DEVICE LOCATOR DESIGNATION

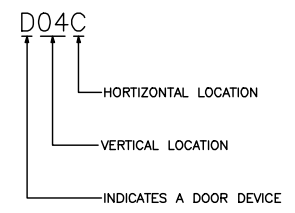

NOTE:
THE "DEVICE LOCATOR DESIGNATION" IS LOCATED ON THE ELEMENTARY AND WIRING DIAGRAMS.

MTM PLC CONTROL DOOR – FRONT VIEW
AUTO THROVER SYSTEM : CLOSED TRANSITION

PLC DOOR DETAIL

- NOTES:
1. ENGRAVED NAMEPLATE BLANK P/N 80420-607-03. TEXT HEIGHT .22".
 2. ENGRAVED NAMEPLATE BLANK P/N 80258-537-03. TEXT HEIGHT .175".
 3. ENGRAVED NAMEPLATE BLANK P/N 80420-607-03. TEXT HEIGHT .175".

JOB NAME:	JHU/APL SUBS 2 & 3 CONSOLIDATION	EQUIPMENT DESIGNATION:	SUBSTATION A
JOB LOCATION:	LAUREL MD	EQUIPMENT TYPE:	PZ4 SWITCHGEAR
DRAWN BY:	S.KUNDU/AJEER	DRAWING TYPE:	DOOR DETAIL
ENGR:	S.ADONGO		
DATE:	NOVEMBER 11 2009	by Schneider Electric	
DRAWING STATUS:	RECORD	DWG#	D27452521-006-01

REV	DESCRIPTION	BY	DATE						
-	----	---	---/---/---	-	----	---	---/---/---	-	----

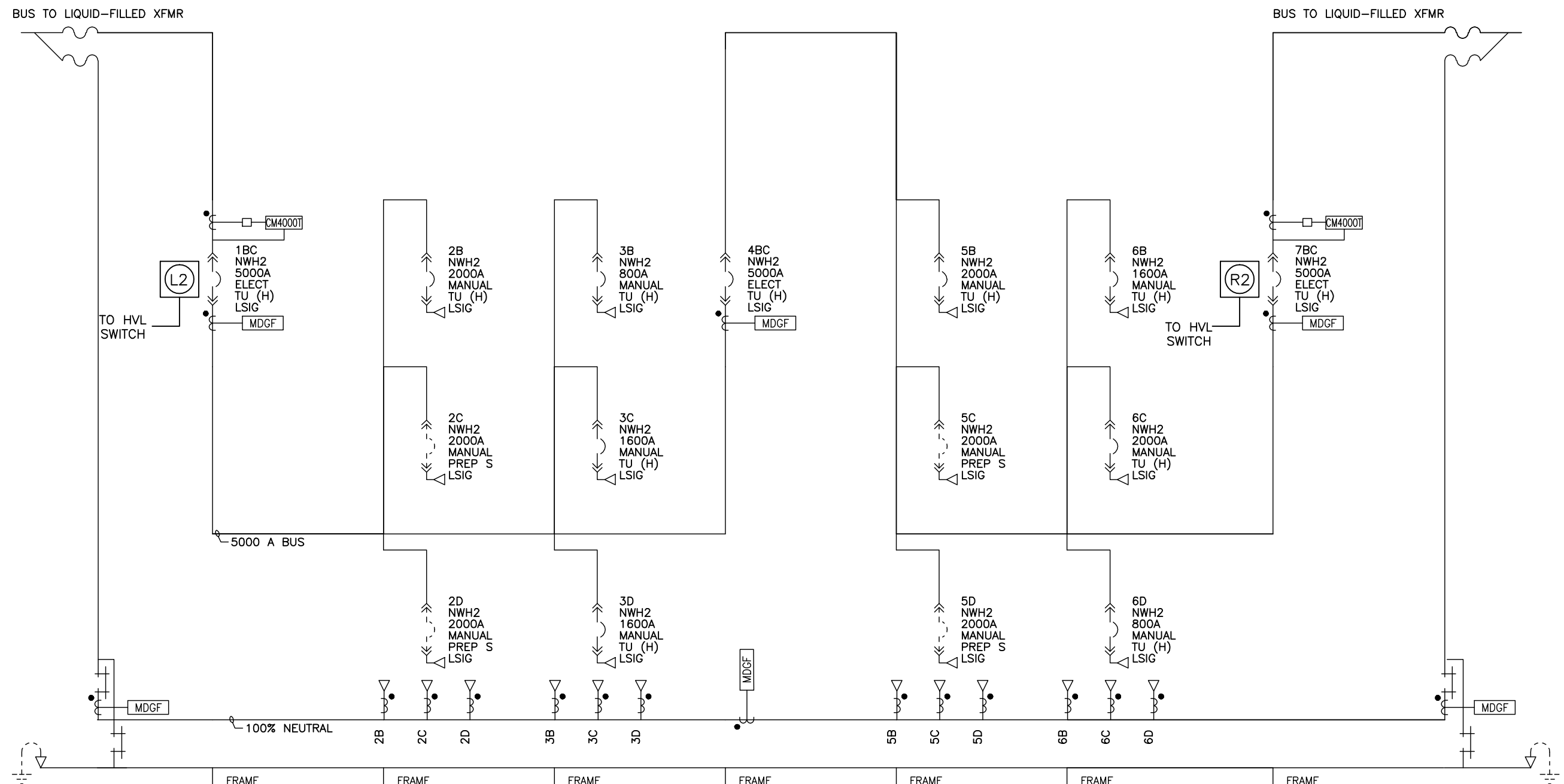

ONE LINE

JOB NAME:	JHU/APL SUBS 2 & 3 CONSOLIDATION	EQUIPMENT DESIGNATION:	SUBSTATION A
JOB LOCATION:	LAUREL MD	EQUIPMENT TYPE:	PZ4 SWITCHGEAR
DRAWN BY:	S.KUNDU/A.JEER	DRAWING TYPE:	ONE LINE
ENGR:	S.ADONGO		
DATE:	NOVEMBER 11 2009	by Schneider Electric	
DRAWING STATUS:	RECORD	DWG#	027452521-006-01
		PG	1 OF 1
		REV	-

REV	DESCRIPTION	BY	DATE	-	----	--	---/---/---	-	----	--	---/---/---	-	----	--	---/---/---
-	----	--	---/---/---	-	----	--	---/---/---	-	----	--	---/---/---	-	----	--	---/---/---

POWER-ZONE 4 SWITCHGEAR – MASTERPACT POWER CIRCUIT BREAKER TABLE

CELL NO	BREAKER DESIGNATION	BKR TYPE	BKR OPER	BREAKER TRIP UNIT	FRAME SIZE	SENSOR PLUG	TRIP SETTING	RATING PLUG	BKR AIC	TRIP PARAM	LUGS PER PHASE: MECHANICAL					BREAKER AND CRADLE ACCESSORIES (NON STANDARD)	
											QTY	A,B,C SIZE	QTY	NEUT SIZE	QTY		GND SIZE
1BC	MAIN LEFT	NWH2	ELECT	HARMONIC	5000A	5000A	5000A	A	85KA	LSIG	-	Transformer-In	-	-	1	3/0 - 750kcmil	OF8,CE3,CT1,CD2,MCH,MX1,XF,M2C,COM,MCT,PL,PBL,CDM,
2B	SPARE	NWH2	MANUAL	HARMONIC	2000A	2000A	2000A	A	85KA	LSIG	6	3/0 - 750kcmil	6	3/0 - 750kcmil	-	-	OF12,CE3,CT1,CD2,MN,M2C,COM,PL,CDM,
2C	SPACE	(NWH2)	-----	(PREP SPACE)	2000A	-----	-----	-	85KA	(LSIG)	6	3/0 - 750kcmil	6	3/0 - 750kcmil	-	-	OF12,CE3,CT1,CD2,MN,M2C,COM,
2D	SPACE	(NWH2)	-----	(PREP SPACE)	2000A	-----	-----	-	85KA	(LSIG)	6	3/0 - 750kcmil	6	3/0 - 750kcmil	-	-	OF12,CE3,CT1,CD2,MN,M2C,COM,
3B	FB5	NWH2	MANUAL	HARMONIC	800A	800A	800A	A	85KA	LSIG	3	3/0 - 750kcmil	3	3/0 - 750kcmil	-	-	OF12,CE3,CT1,CD2,MN,M2C,COM,PL,CDM,
3C	FB4	NWH2	MANUAL	HARMONIC	1600A	1200A	1200A	A	85KA	LSIG	4	3/0 - 750kcmil	4	3/0 - 750kcmil	-	-	OF12,CE3,CT1,CD2,MN,M2C,COM,PL,CDM,
3D	FBK	NWH2	MANUAL	HARMONIC	1600A	1000A	950A	B	85KA	LSIG	3	3/0 - 750kcmil	3	3/0 - 750kcmil	-	-	OF12,CE3,CT1,CD2,MN,M2C,COM,PL,CDM,
4BC	TIE	NWH2	ELECT	HARMONIC	5000A	5000A	5000A	A	85KA	LSIG	-	Tie	-	-	-	-	OF8,CE3,CT1,CD2,MCH,MX1,XF,M2C,COM,PL,PBL,CDM,
5B	SPARE	NWH2	MANUAL	HARMONIC	2000A	2000A	2000A	A	85KA	LSIG	6	3/0 - 750kcmil	6	3/0 - 750kcmil	-	-	OF12,CE3,CT1,CD2,MN,M2C,COM,PL,CDM,
5C	SPACE	(NWH2)	-----	(PREP SPACE)	2000A	-----	-----	-	85KA	(LSIG)	6	3/0 - 750kcmil	6	3/0 - 750kcmil	-	-	OF12,CE3,CT1,CD2,MN,M2C,COM,
5D	SPACE	(NWH2)	-----	(PREP SPACE)	2000A	-----	-----	-	85KA	(LSIG)	6	3/0 - 750kcmil	6	3/0 - 750kcmil	-	-	OF12,CE3,CT1,CD2,MN,M2C,COM,
6B	FB2	NWH2	MANUAL	HARMONIC	1600A	1000A	950A	B	85KA	LSIG	3	3/0 - 750kcmil	3	3/0 - 750kcmil	-	-	OF12,CE3,CT1,CD2,MN,M2C,COM,PL,CDM,
6C	FB3	NWH2	MANUAL	HARMONIC	2000A	2000A	1600A	A	85KA	LSIG	5	3/0 - 750kcmil	5	3/0 - 750kcmil	-	-	OF12,CE3,CT1,CD2,MN,M2C,COM,PL,CDM,
6D	FBCU	NWH2	MANUAL	HARMONIC	800A	250A	200A	A	85KA	LSIG	1	3/0 - 750kcmil	1	3/0 - 750kcmil	-	-	OF12,CE3,CT1,CD2,MN,M2C,COM,PL,CDM,
7BC	MAIN RIGHT	NWH2	ELECT	HARMONIC	5000A	5000A	5000A	A	85KA	LSIG	-	Transformer-In	-	-	1	3/0 - 750kcmil	OF8,CE3,CT1,CD2,MCH,MX1,XF,M2C,COM,MCT,PL,PBL,CDM,

LEGEND (ACCESSORIES)

STANDARD ACCESSORIES		NON-STANDARD ACCESSORIES	
OF4	AUX CONTACTS (STD)	MX1	SHUNT TRIP
UC1	ZSI SECONDARIES (STD)	XF	SHUNT CLOSE
UC2	MODIFIED DIFFERENTIAL GROUND FAULT (STD)	MCH	SPRING CHARGING MOTOR
UC3	24VDC POWER SUPPLY (STD)	MX1C	SHUNT TRIP WITH COMM'S
SDE1	ELECTRICAL FAULT ALARM CONTACT (STD)	XFC	SHUNT CLOSE WITH COMM'S
CPL	CRADLE PADLOCK ATTACHMENT	PF	READY TO CLOSE CONTACT
		OF(X)	AUX CONTACTS (X=QTY)
		EF(X)	CONNECTED AND CLOSED SWITCHES (X=QTY)
CE(X)	CONNECTED CELL SWITCHES (X=QTY)	SH	SHUTTERS
CT(X)	TEST CELL SWITCHES (X=NUMBER OF)	MCT	METERING CT
CD(X)	DISCONNECTED CELL SWITCHES (X=QTY)	PBL	PUSH BUTTON INTERLOCK COVER
COM	COMMUNICATION	AR	AUTOMATIC RESET
M2C	2 PROGRAMMABLE CONTACT MODULE	CDM	OPERATIONS COUNTER
M6C	6 PROGRAMMABLE CONTACT MODULE	PL	PADLOCK ATTACHMENT(REQD FOR KEYLOCK)
SDE2	ADDITIONAL ELECTRICAL FAULT ALARM CONTACT	K	KEY INTERLOCK
RES	ELECTRICAL RESET	CK	CRADLE KEY INTERLOCK
MN	UNDERVOLTAGE TRIP	--	---
MX2	SHUNT TRIP	--	---

NOTES

- ▲ ENGRAVED NAMEPLATES SHALL BE WHITE BACKGROUND WITH BLACK LETTERS.
- ▲ MECHANICAL LUG QUANTITIES ARE BASED ON COPPER CABLES.

JOB NAME:	JHU/APL SUBS 2 & 3 CONSOLIDATION	EQUIPMENT DESIGNATION:	SUBSTATION A
JOB LOCATION:	LAUREL MD	EQUIPMENT TYPE:	PZ4 SWITCHGEAR
DRAWN BY:	S.KUNDU/A.JEER	DRAWING TYPE:	DEVICE TABLE
ENGR:	S.ADONGO	 by Schneider Electric	
DATE:	NOVEMBER 11 2009	DWG#	027452521-006-02
DRAWING STATUS:	RECORD	PG 1	OF 1
		REV	-

REV	DESCRIPTION	BY	DATE						
-	----	--	--/--/--	-	----	--	--/--/--	-	----
-	----	--	--/--/--	-	----	--	--/--/--	-	----

PURPOSE: TO PREVENT OPERATION OF HV SWITCH 1 WHEN BREAKER A IS CLOSED.
TO PREVENT OPERATION OF HV SWITCH 2 WHEN BREAKER B IS CLOSED.
NORMAL OPERATING CONDITION: SOURCE 1 FEEDING LOAD 1, SOURCE 2
FEEDING LOAD 2, BREAKERS A AND B CLOSED, TIE BREAKER OPEN.
HV SWITCHES 1 AND 2 CLOSED.

- TO OPERATE HV SWITCH 1:
1. OPEN BREAKER A, IF CLOSED, AND ROTATE KEY L2 TO LOCK BREAKER OPEN - KEY IS NOW FREE.
 2. REMOVE KEY L2 FROM BREAKER A AND INSERT KEY INTO LOCK ON HV SWITCH 1.
 3. ROTATE KEY L2 TO UNLOCK HV SWITCH 1 - KEY IS NOW HELD CAPTIVE.
 4. OPEN OR CLOSE HV SWITCH 1.
 5. REVERSE PROCEDURE TO CLOSE BREAKER A.

- TO OPERATE HV SWITCH 2:
1. OPEN BREAKER B, IF CLOSED, AND ROTATE KEY R2 TO LOCK BREAKER OPEN - KEY IS NOW FREE.
 2. REMOVE KEY R2 FROM BREAKER B AND INSERT KEY INTO LOCK ON HV SWITCH 2.
 3. ROTATE KEY R2 TO UNLOCK HV SWITCH 2 - KEY IS NOW HELD CAPTIVE.
 4. OPEN OR CLOSE HV SWITCH 2.
 5. REVERSE PROCEDURE TO CLOSE BREAKER B.

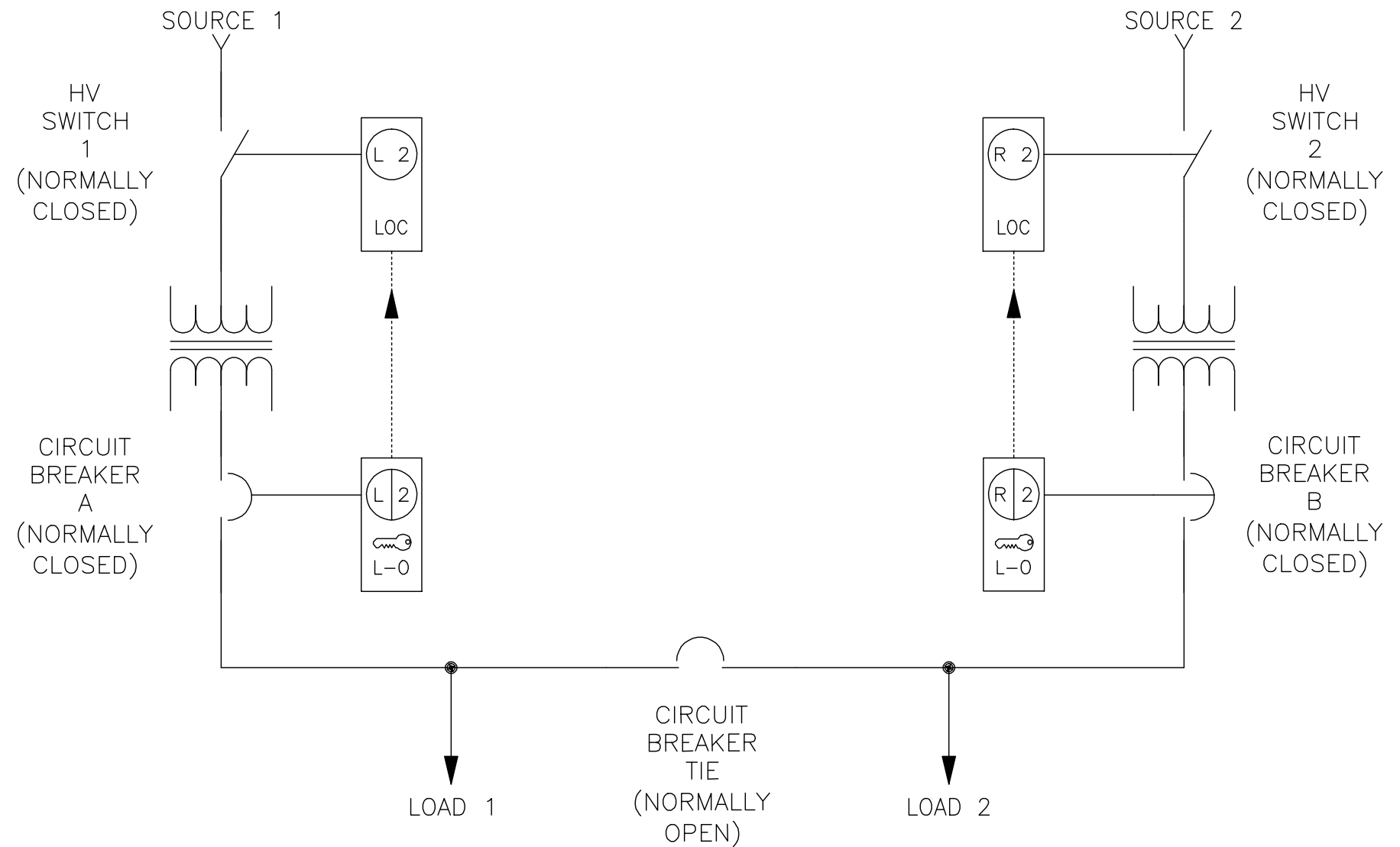

NOTE:
1. THIS SYSTEM USES ONE (1) L2 AND (1) R2 KEY ONLY. ANY SPARE KEYS MUST BE REMOVED AND SECURED TO PREVENT UNAUTHORIZED ACCESS.

MTM - KEY INTERLOCK DIAGRAM

JOB NAME:	JHU/APL SUBS 2 & 3 CONSOLIDATION	EQUIPMENT DESIGNATION:	SUBSTATION A
JOB LOCATION:	LAUREL MD	EQUIPMENT TYPE:	PZ4 SWITCHGEAR
DRAWN BY:	S.KUNDU/AJEER	DRAWING TYPE:	KEY INTERLOCK SCHEME
ENGR:	S.ADONGO		
DATE:	NOVEMBER 11 2009	<small>by Schneider Electric</small>	
DRAWING STATUS:	APPROVAL	DWG#	K27452521-006-01
		PG1	OF1
		REV -	

REV	DESCRIPTION	BY	DATE						
A	SWAPPED L1/N1 RAT-HOLES	SA	03/30/2010	-	----				

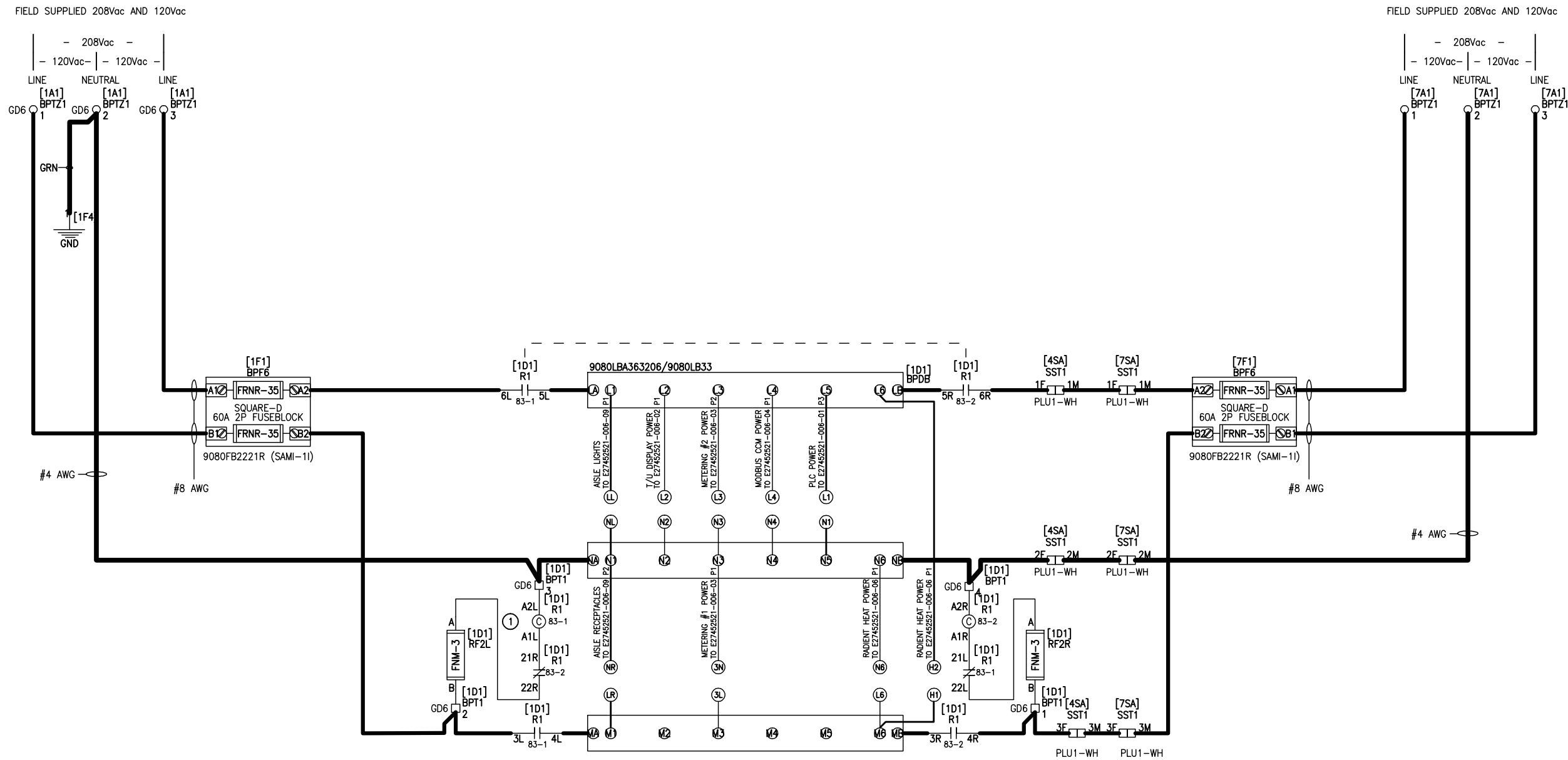

CONTROL POWER 240VAC AND 120VAC

- NOTES:
1. ALL WIRING TO BE TYPE "SIS" (UL LISTED)
 2. ALL CONTROL FUSES MOUNTED IN FUSED PULLOUTS.
 3. USE #14 AWG WIRE UNLESS OTHERWISE NOTED.

① LC2D50G7 : REVERSING CONTACTOR (70A RESISTIVE) USE: (2) LC1D50G7, (1) LA9D4002

JOB NAME:	JHU/APL SUBS 2 & 3 CONSOLIDATION	EQUIPMENT DESIGNATION:	SUBSTATION A
JOB LOCATION:	LAUREL MD	EQUIPMENT TYPE:	PZ4 SWITCHGEAR
DRAWN BY:	S.KUNDU/AJEER	DRAWING TYPE:	ELEMENTARY DIAGRAM
ENGR:	S.ADONGO		
DATE:	NOVEMBER 11 2009		
DRAWING STATUS:	RECORD	DWG#	E2745251-006-01
		PG1	OF 6
		REV A	

REV	DESCRIPTION	BY	DATE	B	REVERSED X2/H2 ON X25 PT	SA	04/06/2010	-	----	--	---/---/---
A	REVERSED PT WIRING ON 7D AND XD1B ON 1A	SA	03/30/2010	C	UPDATED PT TERMINAL WIRING	SA	04/07/2010	-	----	--	---/---/---

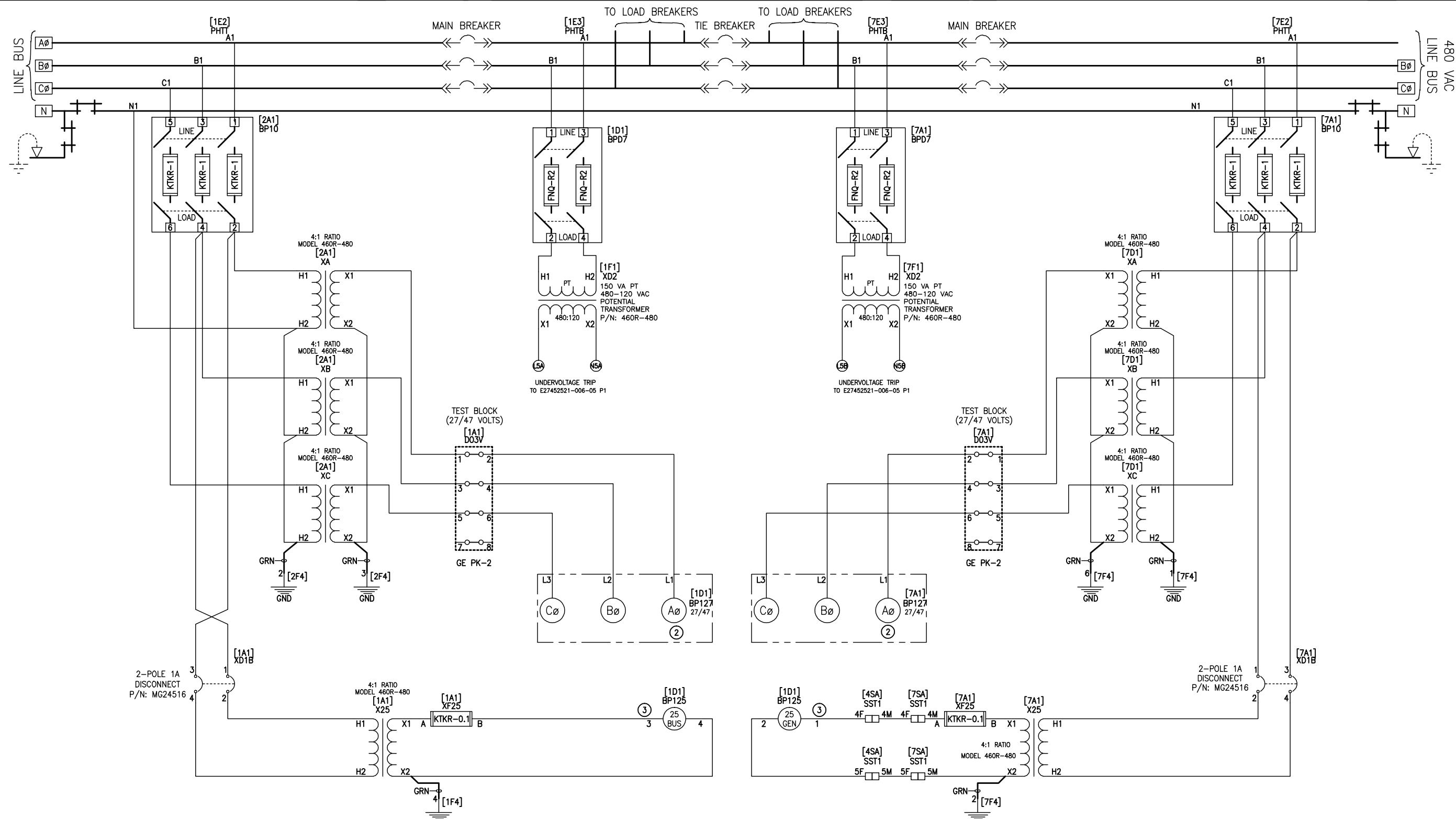

INPUT POWER TO 27/47 RELAY AND U/V TRIP CIRCUIT

- NOTES:
- ALL WIRING TO BE TYPE "SIS" (UL LISTED)
 - ALL CONTROL FUSES MOUNTED IN FUSED PULLOUTS.
 - USE #14 AWG WIRE UNLESS OTHERWISE NOTED.

① CROMPTON 27/47 P/N 252PSGUPQBXC6EB

JOB NAME:	JHU/APL SUBS 2 & 3 CONSOLIDATION	EQUIPMENT DESIGNATION:	SUBSTATION A
JOB LOCATION:	LAUREL MD	EQUIPMENT TYPE:	PZ4 SWITCHGEAR
DRAWN BY:	S.KUNDU/AJEER	DRAWING TYPE:	ELEMENTARY DIAGRAM
ENGR:	S.ADONGO		
DATE:	NOVEMBER 11 2009		
DRAWING STATUS:	RECORD	DWG#	E27452521-006-01

REV	DESCRIPTION	BY	DATE						
-	-	-	-	-	-	-	-	-	-

FROM E27452521-006-01 P1
120 VAC CONTROL POWER

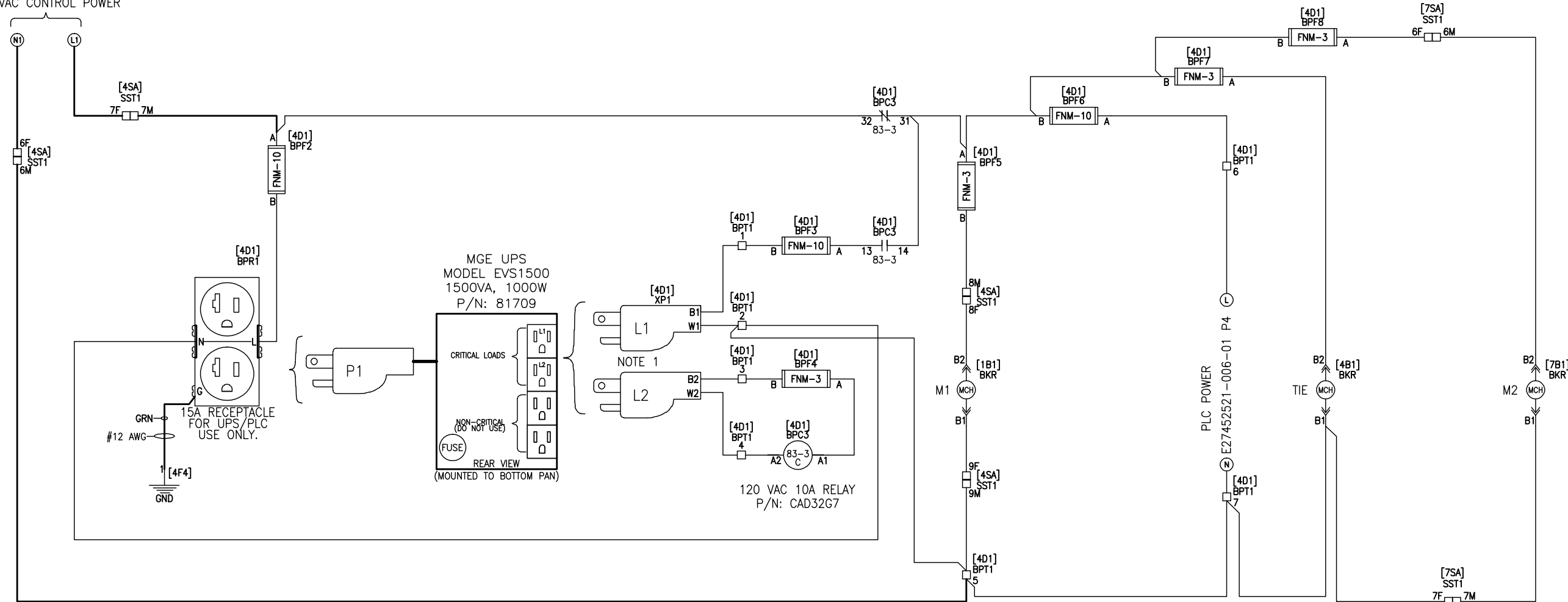

NOTES:

1. ALL WIRING TO BE TYPE "SIS" (U.L. LISTED).
2. ALL CONTROL FUSES MOUNTED IN FUSED PULLOUTS.
3. USE #14 AWG WIRE UNLESS OTHERWISE NOTED.
4. CUT GREEN WIRE IN CORDS BACK TO THE INSULATION. DO NOT GROUND.
5. CABLES FROM UPS ARE 3/C #14 POWER.
6. FUSE BLOCKS SHIP WITH SLUGS (BUSSMAN TYPE NNB-R).

120VAC UPS CONTROL POWER, PLC

JOB NAME:	JHU/APL SUBS 2 & 3 CONSOLIDATION	EQUIPMENT DESIGNATION:	SUBSTATION A
JOB LOCATION:	LAUREL MD	EQUIPMENT TYPE:	PZ4 SWITCHGEAR
DRAWN BY:	S.KUNDU/AJEER	DRAWING TYPE:	ELEMENTARY DIAGRAM
ENGR:	S.ADONGO		
DATE:	NOVEMBER 11 2009	by Schneider Electric	
DRAWING STATUS:	RECORD	DWG#	E27452521-006-01

REV	DESCRIPTION	BY	DATE						
-	-	-	-	-	-	-	-	-	-

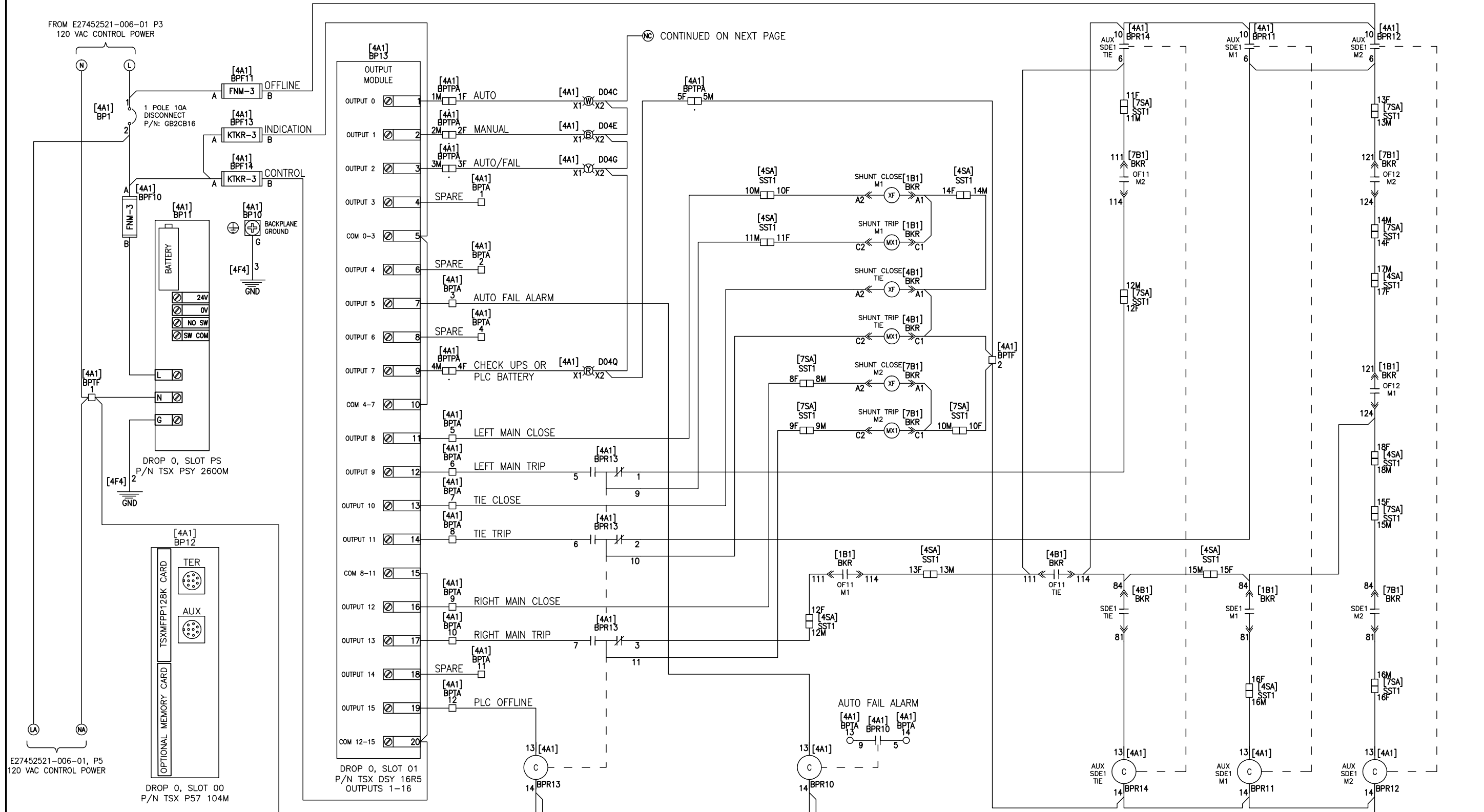

- NOTES:
1. ALL WIRING TO BE TYPE "SIS" (UL LISTED).
 2. ALL CONTROL FUSES MOUNTED IN FUSED PULLOUTS.
 3. PULL APART TERMINAL BLOCKS - TOP OR RIGHT PORTION (MALE) WILL BE MOUNTED TO THE PAN. BOTTOM OR LEFT PORTION (FEMALE) WILL BE USED ON DOOR HARNESS.
 4. BREAKER SHOWN IN OPEN AND CONNECTED POSITION. ALL RELAYS SHOWN DE-ENERGIZED, UNLATCHED AND RESET.

JOB NAME:	JHU/APL SUBS 2 & 3 CONSOLIDATION	EQUIPMENT DESIGNATION:	SUBSTATION A
JOB LOCATION:	LAUREL MD	EQUIPMENT TYPE:	PZ4 SWITCHGEAR
DRAWN BY:	S.KUNDU/AJEER	DRAWING TYPE:	ELEMENTARY DIAGRAM
ENGR:	S.ADONGO		
DATE:	NOVEMBER 11 2009	by Schneider Electric	
DRAWING STATUS:	RECORD	DWG#	E27452521-006-01

REV	DESCRIPTION	BY	DATE						
-	-	-	-	-	-	-	-	-	-

FROM E27452521-006-01 P4
120 VAC CONTROL POWER

CONTINUED FROM PREVIOUS PAGE (NC)

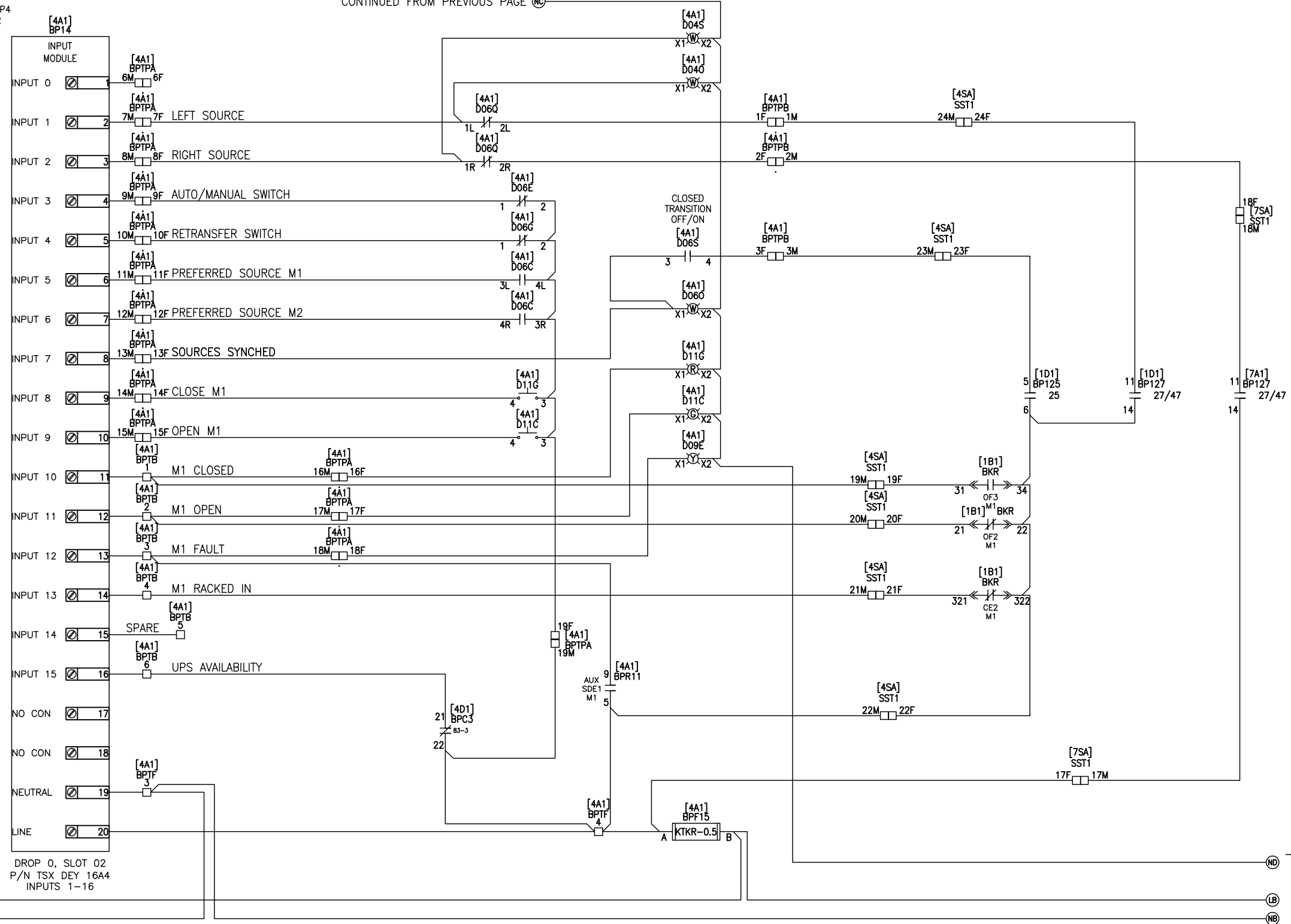

DROP 0, SLOT 02
P/N TSX DEY 16A4
INPUTS 1-16

CONTINUED ON NEXT PAGE

- NOTES:
1. ALL WIRING TO BE TYPE "SIS" (UL LISTED).
 2. ALL CONTROL FUSES MOUNTED IN FUSED PULLOUTS.
 3. PULL APART TERMINAL BLOCKS - TOP OR RIGHT PORTION (MALE) WILL BE MOUNTED TO THE PAN. BOTTOM OR LEFT PORTION (FEMALE) WILL BE USED ON DOOR HARNESS.
 4. BREAKER SHOWN IN OPEN AND CONNECTED POSITION. ALL RELAYS SHOWN DE-ENERGIZED, UNLATCHED AND RESET.

JOB NAME:	JHU/APL SUBS 2 & 3 CONSOLIDATION	EQUIPMENT DESIGNATION:	SUBSTATION A
JOB LOCATION:	LAUREL MD	EQUIPMENT TYPE:	PZ4 SWITCHGEAR
DRAWN BY:	S.KUNDU/AJEER	DRAWING TYPE:	ELEMENTARY DIAGRAM
ENGR:	S.ADONGO		
DATE:	NOVEMBER 11 2009		
DRAWING STATUS:	RECORD	DWG#	E27452521-006-01

REV	DESCRIPTION	BY	DATE						
-	-	-	-	-	-	-	-	-	-

FROM E27452521-006-01 P4
120 VAC CONTROL POWER

CONTINUED FROM PREVIOUS PAGE (NB)

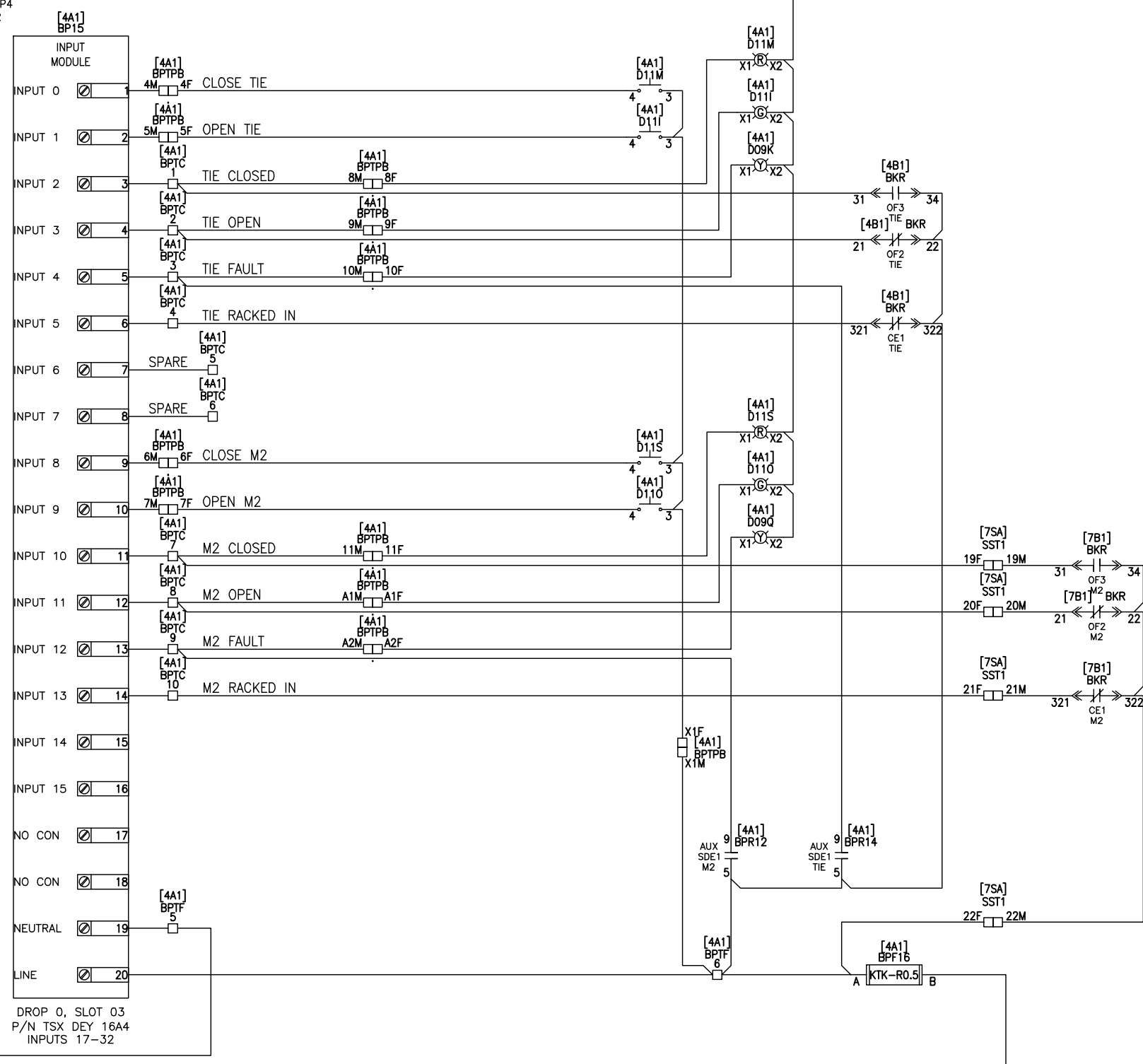

DROP 0, SLOT 03
P/N TSX DEY 16A4
INPUTS 17-32

NOTES:

1. ALL WIRING TO BE TYPE "SIS" (UL LISTED).
2. ALL CONTROL FUSES MOUNTED IN FUSED PULLOUTS.
3. PULL APART TERMINAL BLOCKS - TOP OR RIGHT PORTION (MALE) WILL BE MOUNTED TO THE PAN. BOTTOM OR LEFT PORTION (FEMALE) WILL BE USED ON DOOR HARNESS.
4. BREAKER SHOWN IN OPEN AND CONNECTED POSITION. ALL RELAYS SHOWN DE-ENERGIZED, UNLATCHED AND RESET.

JOB NAME:	JHU/APL SUBS 2 & 3 CONSOLIDATION	EQUIPMENT DESIGNATION:	SUBSTATION A
JOB LOCATION:	LAUREL MD	EQUIPMENT TYPE:	PZ4 SWITCHGEAR
DRAWN BY:	S.KUNDU/AJEER	DRAWING TYPE:	ELEMENTARY DIAGRAM
ENGR:	S.ADONGO		
DATE:	NOVEMBER 11 2009		
DRAWING STATUS:	RECORD	DWG#	E27452521-006-01

REV	DESCRIPTION	BY	DATE						
-	-	-	-	-	-	-	-	-	-

FROM E27452521-006-01 P1
120 VAC CONTROL POWER

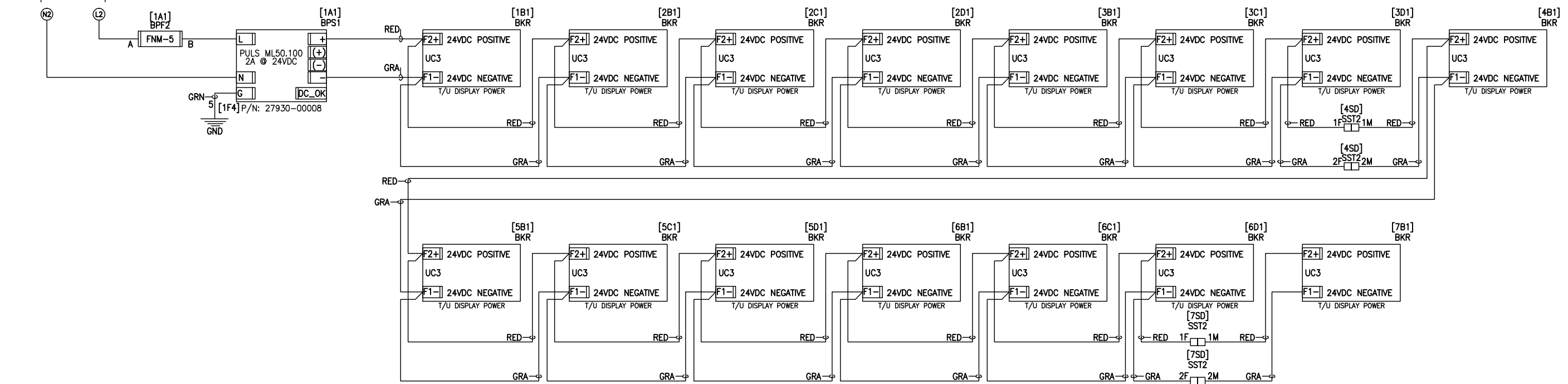

NOTES:

1. ALL WIRING TO BE TYPE "SIS" (UL LISTED)
2. ALL CONTROL FUSES MOUNTED IN FUSED PULLOUTS.
3. USE #14 AWG (RED, GRAY) TWISTED PAIR UNLESS OTHERWISE NOTED.
4. ROUTE ALL TWISTED PAIR WIRES SEPARATELY THROUGH THE BOTTOM WIREWAY.

TRIP UNIT DISPLAY POWER

JOB NAME:	JHU/APL SUBS 2 & 3 CONSOLIDATION	EQUIPMENT DESIGNATION:	SUBSTATION A
JOB LOCATION:	LAUREL MD	EQUIPMENT TYPE:	PZ4 SWITCHGEAR
DRAWN BY:	S.KUNDU/AJEER	DRAWING TYPE:	ELEMENTARY DIAGRAM
ENGR:	S.ADONGO		
DATE:	NOVEMBER 11 2009	<small>by Schneider Electric</small>	
DRAWING STATUS:	RECORD	DWG#	E27452521-006-02
		PG1	OF1
		REV	-

REV	DESCRIPTION	BY	DATE						
-	-	-	-	-	-	-	-	-	-

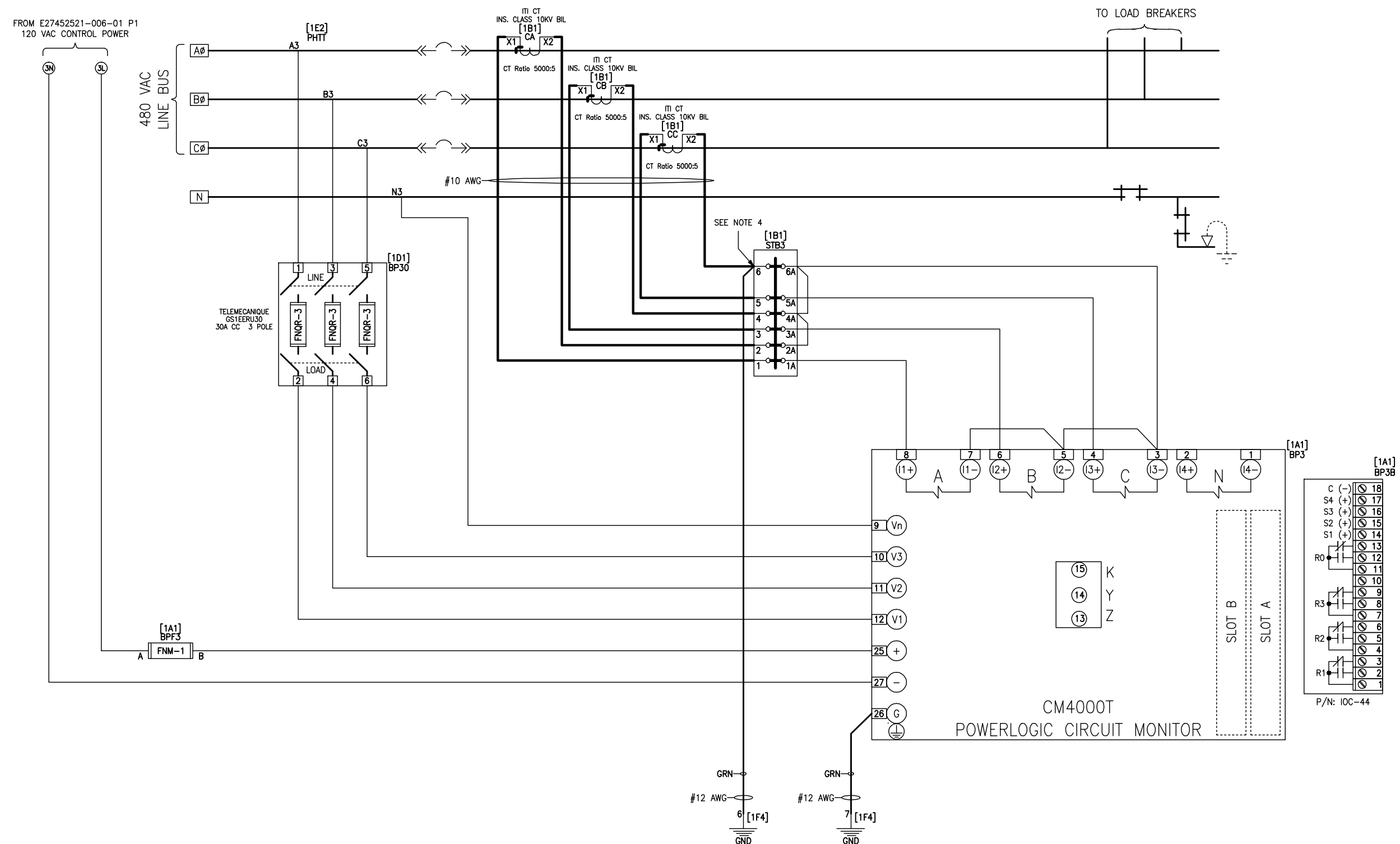

POWERLOGIC CIRCUIT MONITORING

- NOTES:
1. ALL WIRING TO BE TYPE "SIS" (UL LISTED)
 2. ALL CONTROL FUSES MOUNTED IN FUSED PULLOUTS.
 3. USE #14 AWG WIRE UNLESS OTHERWISE NOTED.
 4. GROUNDED TERMINAL OF THE SHORTING BLOCK TO BE A PAN HEAD SCREW.
 5. METERING CT'S ARE SUPPLIED AS A PART OF THE BREAKER'S CRADLE ASSEMBLY.

JOB NAME:	JHU/APL SUBS 2 & 3 CONSOLIDATION	EQUIPMENT DESIGNATION:	SUBSTATION A
JOB LOCATION:	LAUREL MD	EQUIPMENT TYPE:	PZ4 SWITCHGEAR
DRAWN BY:	S.KUNDU/AJEER	DRAWING TYPE:	ELEMENTARY DIAGRAM
ENGR:	S.ADONGO		
DATE:	NOVEMBER 11 2009		
DRAWING STATUS:	RECORD	DWG#	E27452521-006-03

REV	DESCRIPTION	BY	DATE						
-	-	-	-	-	-	-	-	-	-

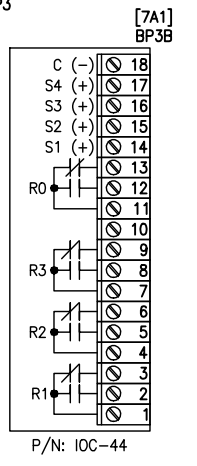
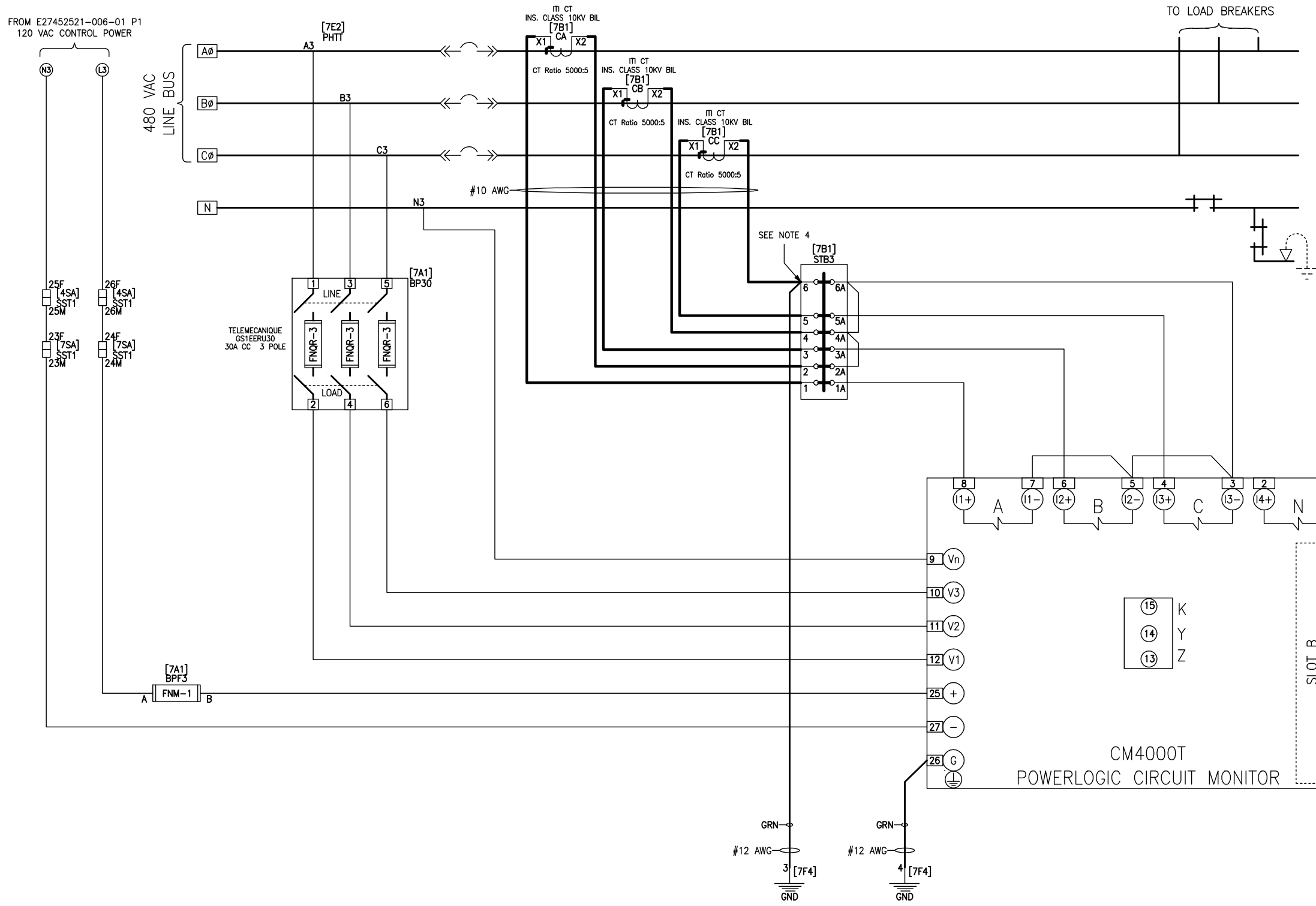

POWERLOGIC CIRCUIT MONITORING

- NOTES:
1. ALL WIRING TO BE TYPE "SIS" (UL LISTED)
 2. ALL CONTROL FUSES MOUNTED IN FUSED PULLOUTS.
 3. USE #14 AWG WIRE UNLESS OTHERWISE NOTED.
 4. GROUNDED TERMINAL OF THE SHORTING BLOCK TO BE A PAN HEAD SCREW.
 5. METERING CT'S ARE SUPPLIED AS A PART OF THE BREAKER'S CRADLE ASSEMBLY.

JOB NAME:	JHU/APL SUBS 2 & 3 CONSOLIDATION	EQUIPMENT DESIGNATION:	SUBSTATION A
JOB LOCATION:	LAUREL MD	EQUIPMENT TYPE:	PZ4 SWITCHGEAR
DRAWN BY:	S.KUNDU/AJEER	DRAWING TYPE:	ELEMENTARY DIAGRAM
ENGR:	S.ADONGO		
DATE:	NOVEMBER 11 2009	by Schneider Electric	
DRAWING STATUS:	RECORD	DWG#	E27452521-006-03

REV	DESCRIPTION	BY	DATE						
-	-	-	-	-	-	-	-	-	-

FROM E27452521-006-01 P1
120 VAC CONTROL POWER

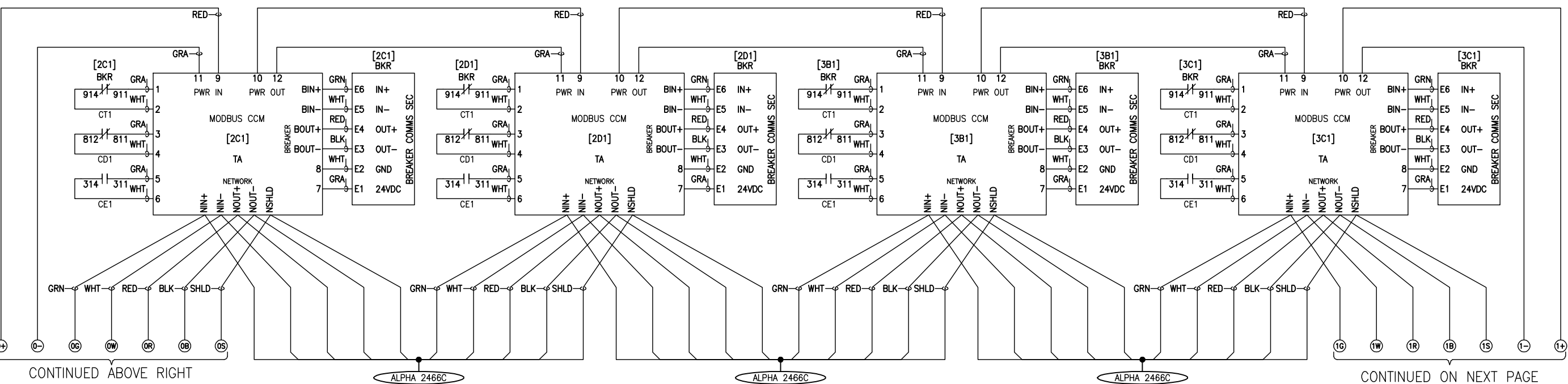
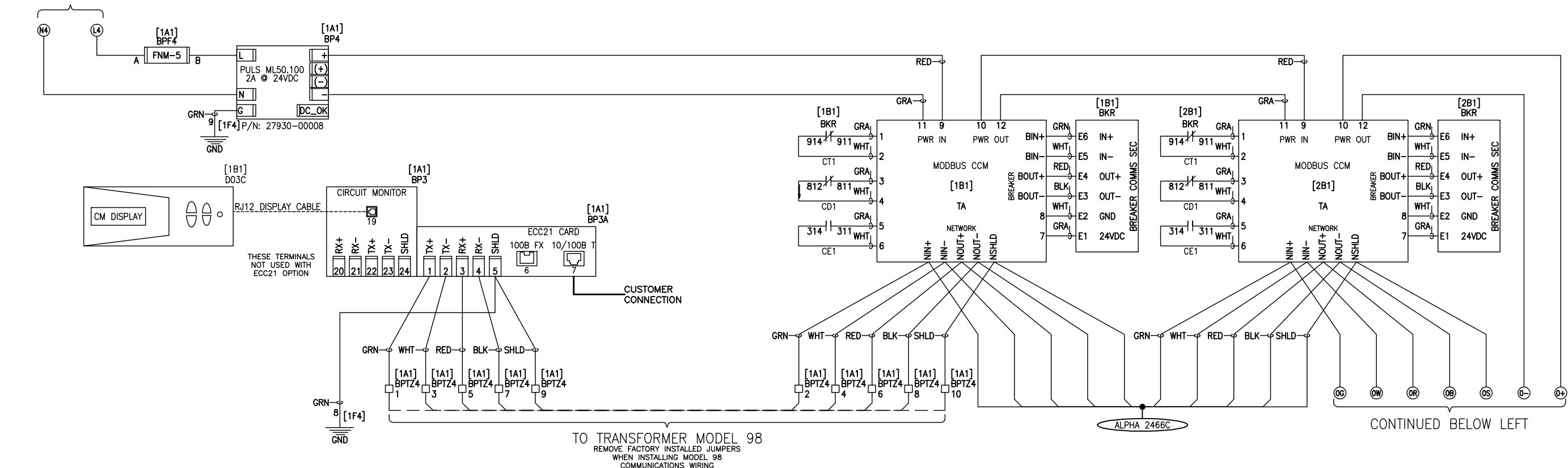

- NOTES:
1. ALL WIRING TO BE TYPE "SIS" (U.L. LISTED).
 2. ALL CONTROL FUSES MOUNTED IN FUSED PULLOUTS.
 3. USE #14 AWG WIRE UNLESS OTHERWISE NOTED.
 4. ONLY THE COMMUNICATIONS CONNECTIONS ARE SHOWN ON THIS DRAWING.
 5. REFER TO THE THREE LINE DIAGRAM FOR VOLTAGE/CURRENT CONNECTIONS (IF ANY).
 6. REFER TO CONTROL SCHEMATICS FOR STATUS INPUT/RELAY OUTPUT (IF ANY).
 7. FIELD WIRING (MODBUS RS485 USING ALPHA 2466C OR EQUIVALENT) = -----

COMMUNICATION SYSTEM SCHEMATIC (RS485)

JOB NAME:	JHU/APL SUBS 2 & 3 CONSOLIDATION	EQUIPMENT DESIGNATION:	SUBSTATION A
JOB LOCATION:	LAUREL MD	EQUIPMENT TYPE:	PZ4 SWITCHGEAR
DRAWN BY:	S.KUNDU/AJEER	DRAWING TYPE:	ELEMENTARY DIAGRAM
ENGR:	S.ADONGO		
DATE:	NOVEMBER 11 2009		
DRAWING STATUS:	RECORD	DWG#	E27452521-006-04

REV	DESCRIPTION	BY	DATE						
-	-	-	-	-	-	-	-	-	-

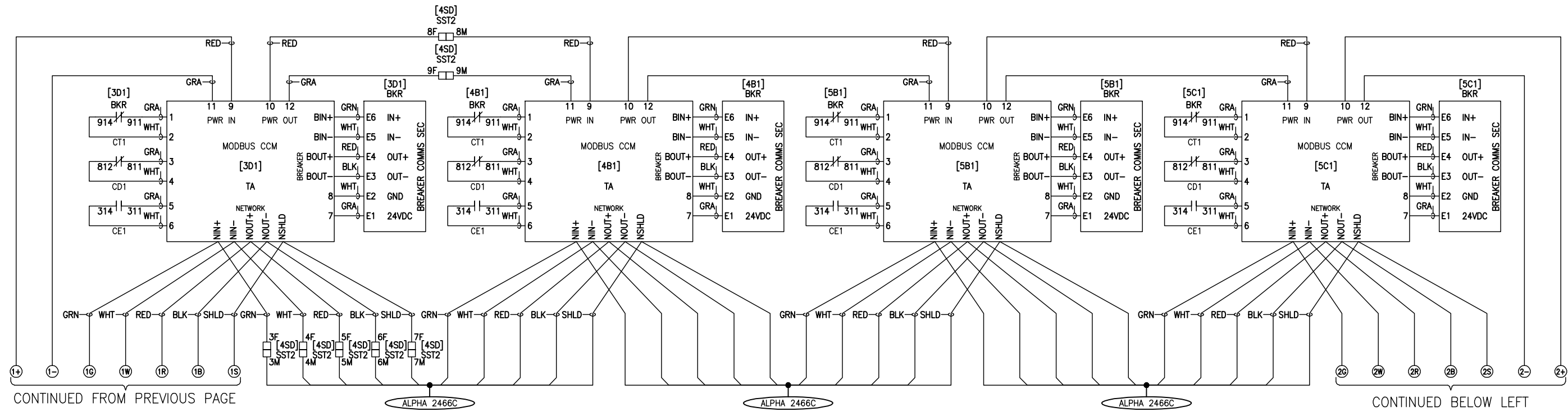

CONTINUED FROM PREVIOUS PAGE

CONTINUED BELOW LEFT

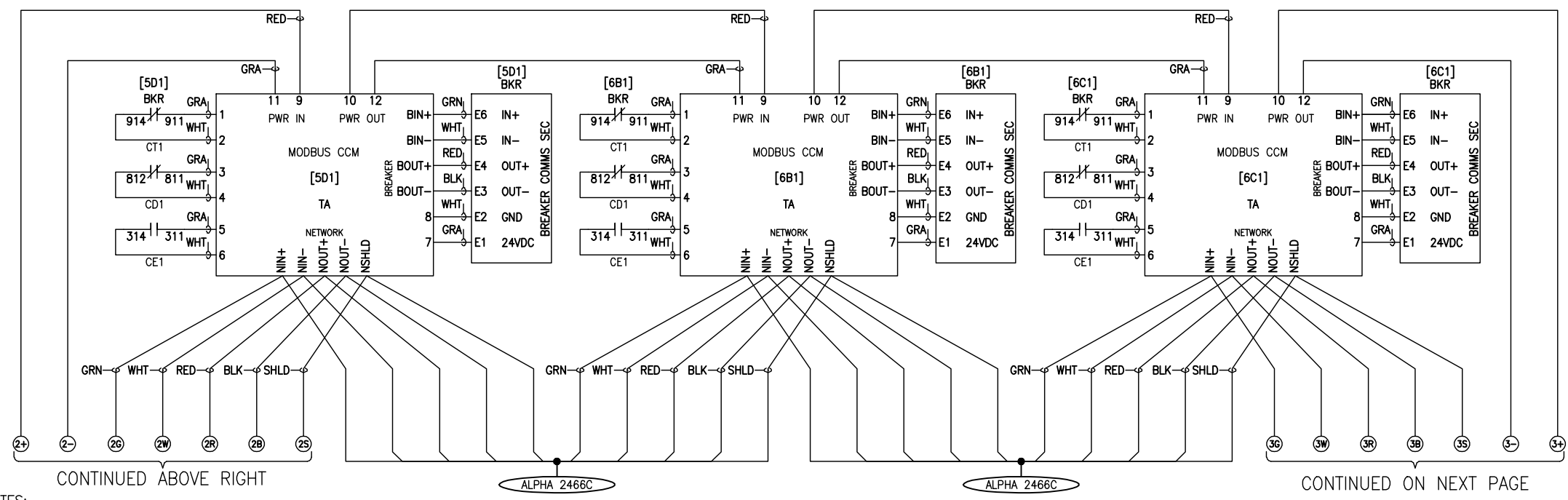

CONTINUED ABOVE RIGHT

CONTINUED ON NEXT PAGE

COMMUNICATION SYSTEM SCHEMATIC (RS485)

- NOTES:
1. ALL WIRING TO BE TYPE "SIS" (U.L. LISTED).
 2. ALL CONTROL FUSES MOUNTED IN FUSED PULLOUTS.
 3. USE #14 AWG WIRE UNLESS OTHERWISE NOTED.
 4. ONLY THE COMMUNICATIONS CONNECTIONS ARE SHOWN ON THIS DRAWING.
 5. REFER TO THE THREE LINE DIAGRAM FOR VOLTAGE/CURRENT CONNECTIONS (IF ANY).
 6. REFER TO CONTROL SCHEMATICS FOR STATUS INPUT/RELAY OUTPUT (IF ANY).
 7. FIELD WIRING (MODBUS RS485 USING ALPHA 2466C OR EQUIVALENT) = - - - - -

JOB NAME:	JHU/APL SUBS 2 & 3 CONSOLIDATION	EQUIPMENT DESIGNATION:	SUBSTATION A
JOB LOCATION:	LAUREL MD	EQUIPMENT TYPE:	PZ4 SWITCHGEAR
DRAWN BY:	S.KUNDU/AJEER	DRAWING TYPE:	ELEMENTARY DIAGRAM
ENGR:	S.ADONGO		
DATE:	NOVEMBER 11 2009	by Schneider Electric	
DRAWING STATUS:	RECORD	DWG#	E27452521-006-04

REV	DESCRIPTION	BY	DATE						
-	----	-	---/---/---	-	----	-	---	---	---

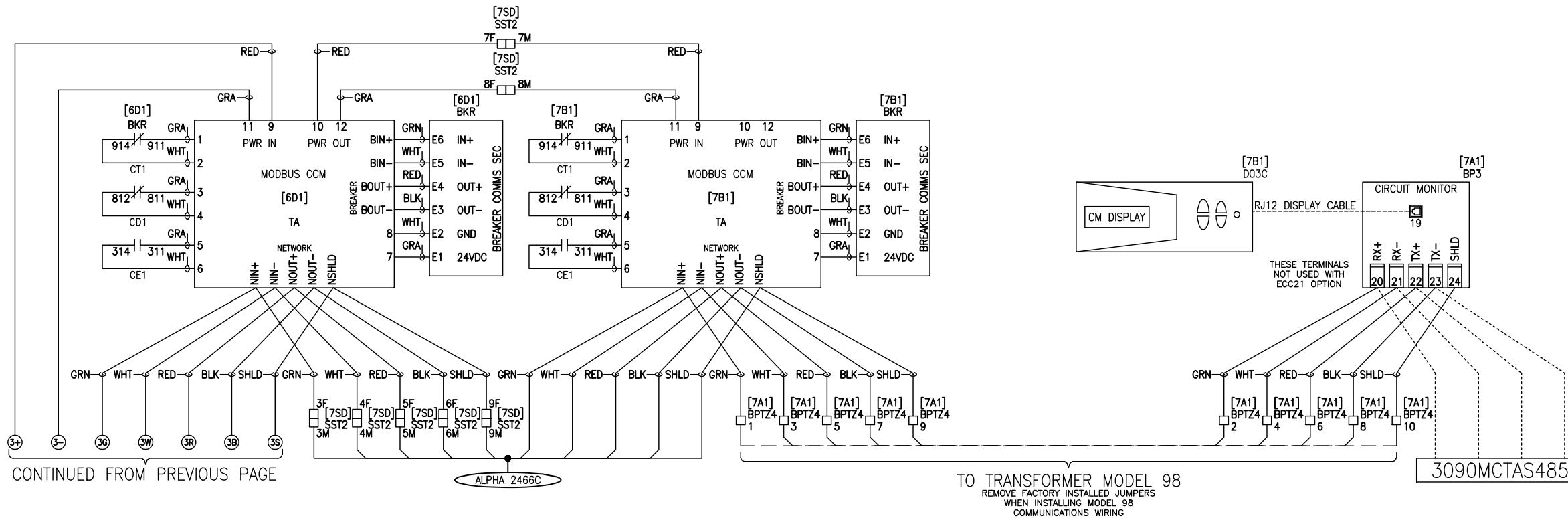

NOTES:

1. ALL WIRING TO BE TYPE "SIS" (U.L. LISTED).
2. ALL CONTROL FUSES MOUNTED IN FUSED PULLOUTS.
3. USE #14 AWG WIRE UNLESS OTHERWISE NOTED.
4. ONLY THE COMMUNICATIONS CONNECTIONS ARE SHOWN ON THIS DRAWING.
5. REFER TO THE THREE LINE DIAGRAM FOR VOLTAGE/CURRENT CONNECTIONS (IF ANY).
6. REFER TO CONTROL SCHEMATICS FOR STATUS INPUT/RELAY OUTPUT (IF ANY).
7. FIELD WIRING (MODBUS RS485 USING ALPHA 2466C) = -----

COMMUNICATION SYSTEM SCHEMATIC (RS485)

JOB NAME:	JHU/APL SUBS 2 & 3 CONSOLIDATION	EQUIPMENT DESIGNATION:	SUBSTATION A
JOB LOCATION:	LAUREL MD	EQUIPMENT TYPE:	PZ4 SWITCHGEAR
DRAWN BY:	S.KUNDU/AJEER	DRAWING TYPE:	ELEMENTARY DIAGRAM
ENGR:	S.ADONGO		
DATE:	NOVEMBER 11 2009	by Schneider Electric	
DRAWING STATUS:	RECORD	DWG#	E27452521-006-04

REV	DESCRIPTION	BY	DATE						
-	-	-	-	-	-	-	-	-	-

FROM E27452521-006-01 PG2
120 VAC CONTROL POWER

FROM E27452521-006-01 PG2
120 VAC CONTROL POWER

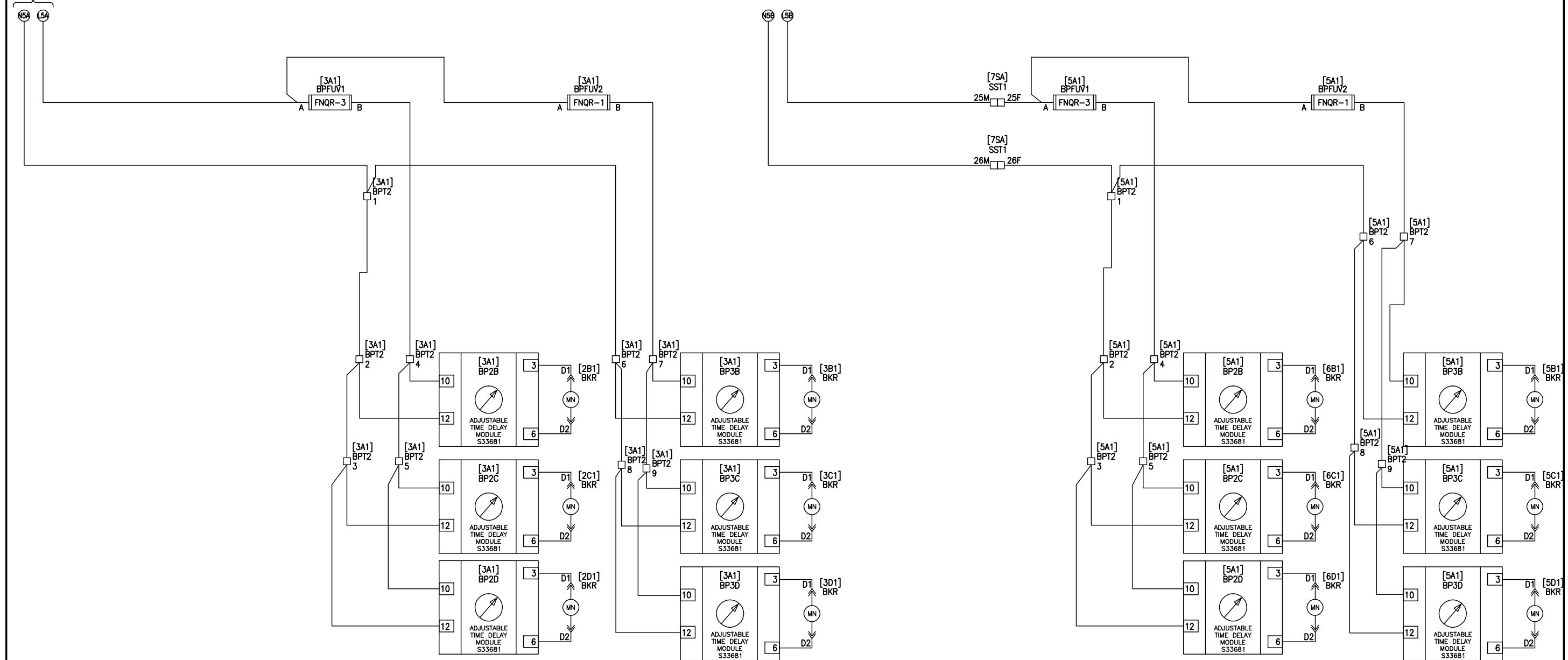

TIME-DELAY UNDERVOLTAGE TRIP

- NOTES:
1. ALL WIRING TO BE TYPE "SIS" (UL LISTED)
 2. ALL CONTROL FUSES MOUNTED IN FUSED PULLOUTS.
 3. USE #14 AWG WIRE UNLESS OTHERWISE NOTED.

JOB NAME:	JHU/APL SUBS 2 & 3 CONSOLIDATION	EQUIPMENT DESIGNATION:	SUBSTATION A
JOB LOCATION:	LAUREL MD	EQUIPMENT TYPE:	PZ4 SWITCHGEAR
DRAWN BY:	S.KUNDU/AJEER	DRAWING TYPE:	ELEMENTARY DIAGRAM
ENGR:	S.ADONGO		
DATE:	NOVEMBER 11 2009	by Schneider Electric	
DRAWING STATUS:	RECORD	DWG#	E27452521-006-05

REV	DESCRIPTION	BY	DATE						
-	-	-	-	-	-	-	-	-	-

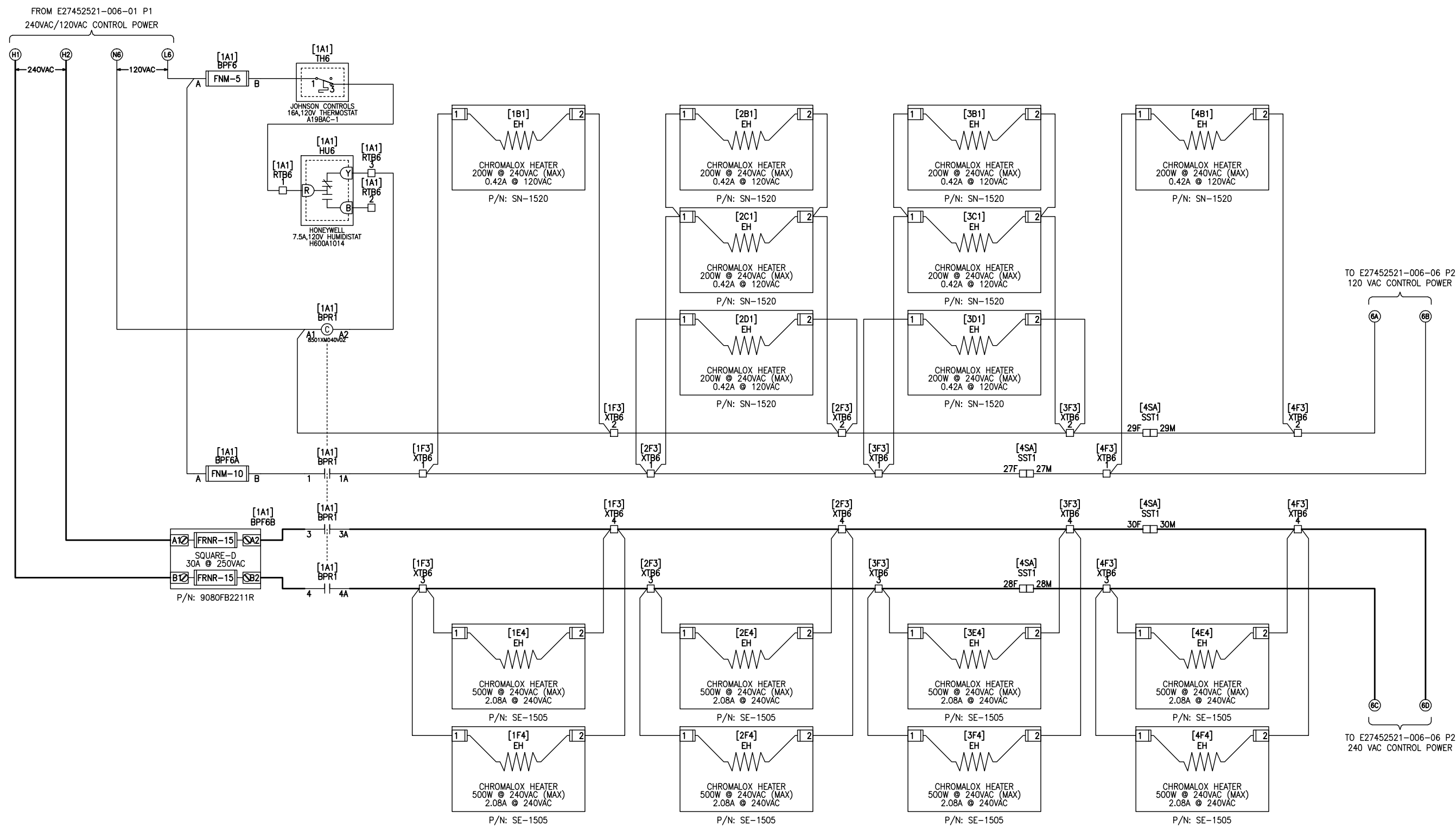

COMPARTMENT STRIP HEATER (NEMA 3R)

- NOTES:
1. ALL WIRING TO BE TYPE "SIS" (UL LISTED).
 2. ALL CONTROL FUSES MOUNTED IN FUSED PULLOUTS.
 3. USE #14 AWG WIRE UNLESS OTHERWISE NOTED.

JOB NAME:	JHU/APL SUBS 2 & 3 CONSOLIDATION	EQUIPMENT DESIGNATION:	SUBSTATION A
JOB LOCATION:	LAUREL MD	EQUIPMENT TYPE:	PZ4 SWITCHGEAR
DRAWN BY:	S.KUNDU/AJEEER	DRAWING TYPE:	ELEMENTARY DIAGRAM
ENGR:	S.ADONGO		
DATE:	NOVEMBER 11 2009		
DRAWING STATUS:	RECORD		



by Schneider Electric

REV	DESCRIPTION	BY	DATE								
-	----	--	--/--/--	--	----	--	--/--/--	--	----	--	--/--/--

FROM E27452521-006-06 P1
240VAC/120VAC CONTROL POWER

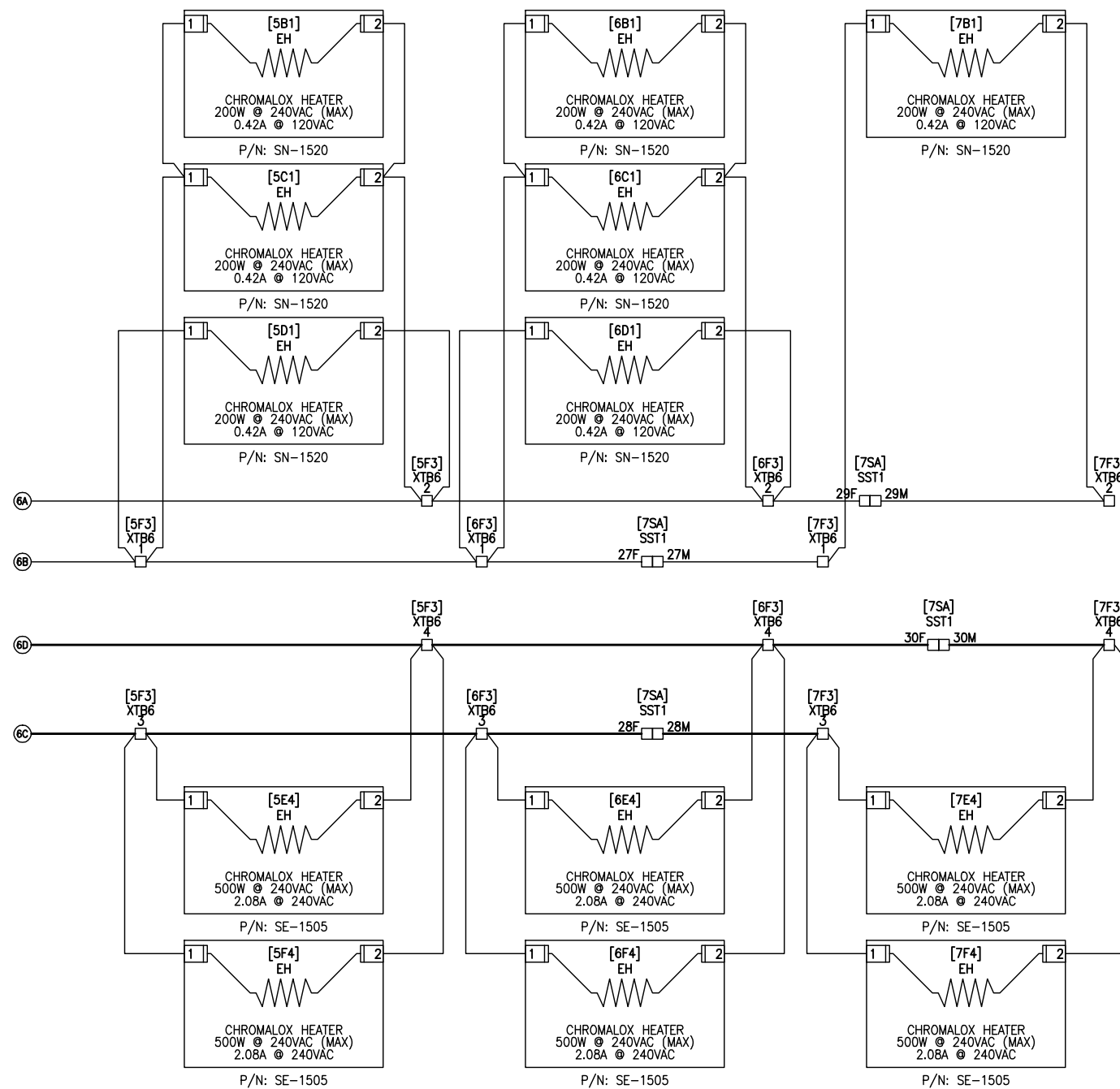

COMPARTMENT STRIP HEATER (NEMA 3R)

- NOTES:
1. ALL WIRING TO BE TYPE "SIS" (UL LISTED).
 2. ALL CONTROL FUSES MOUNTED IN FUSED PULLOUTS.
 3. USE #14 AWG WIRE UNLESS OTHERWISE NOTED.

JOB NAME:	JHU/APL SUBS 2 & 3 CONSOLIDATION	EQUIPMENT DESIGNATION:	SUBSTATION A
JOB LOCATION:	LAUREL MD	EQUIPMENT TYPE:	PZ4 SWITCHGEAR
DRAWN BY:	S.KUNDU/AJEER	DRAWING TYPE:	ELEMENTARY DIAGRAM
ENGR:	S.ADONGO		
DATE:	NOVEMBER 11 2009	by Schneider Electric	
DRAWING STATUS:	RECORD	DWG#	E27452521-006-06

REV	DESCRIPTION	BY	DATE						
-	-	-	-	-	-	-	-	-	-

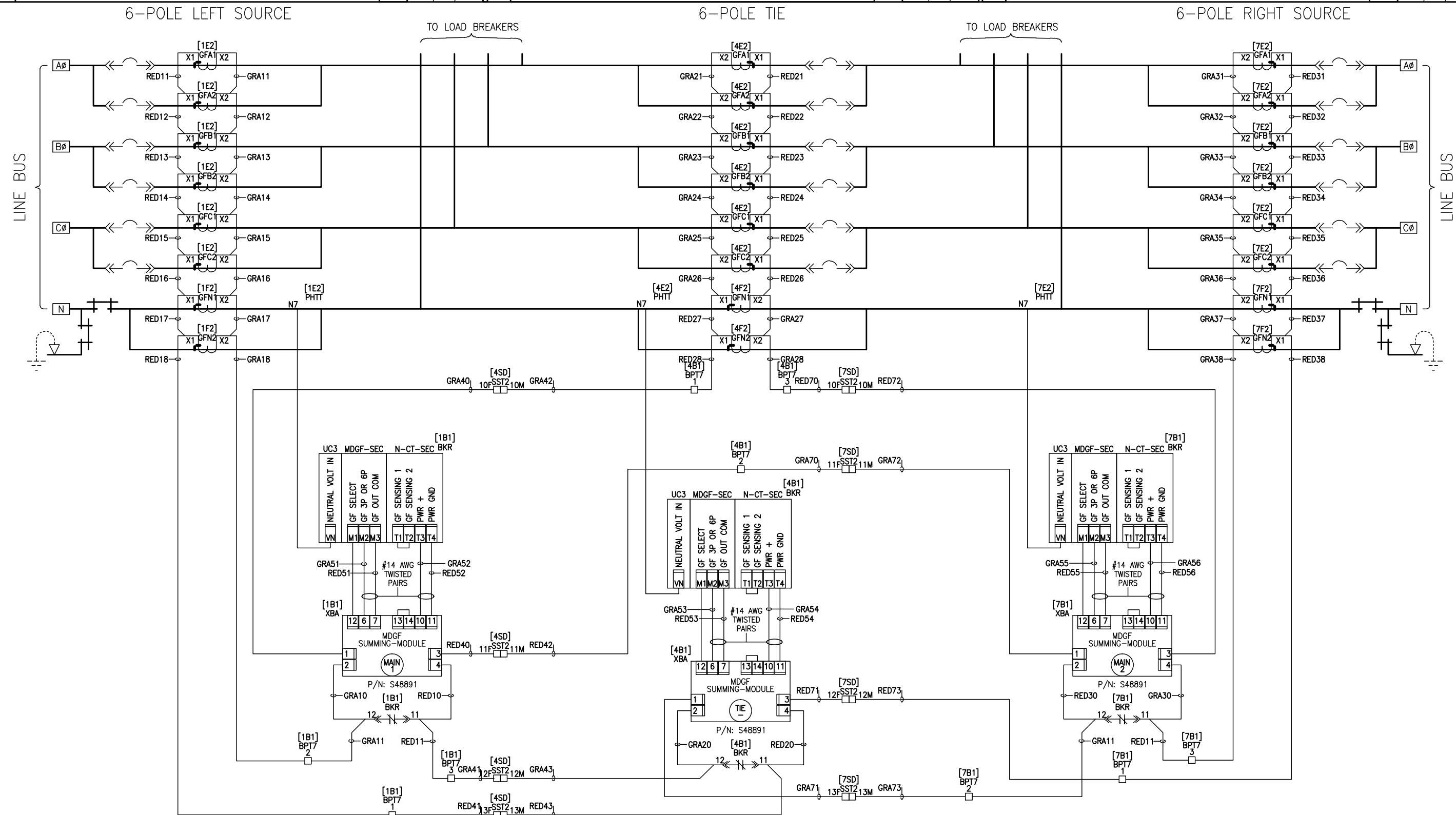

MODIFIED DIFFERENTIAL GROUND FAULT

- NOTES:
1. ALL WIRING TO BE TYPE "SIS" (UL LISTED).
 2. 1000:1 PHASE CT'S (S33579) PROVIDED IN AMAPS ASSEMBLY 80322-206-5X.
 3. USE #14 AWG (RED,GRAY) TWISTED PAIR UNLESS OTHERWISE NOTED.
 4. ROUTE ALL TWISTED PAIR WIRES SEPARATELY THROUGH THE BOTTOM WIREWAY.

JOB NAME:	JHU/APL SUBS 2 & 3 CONSOLIDATION	EQUIPMENT DESIGNATION:	SUBSTATION A
JOB LOCATION:	LAUREL MD	EQUIPMENT TYPE:	PZ4 SWITCHGEAR
DRAWN BY:	S.KUNDU/AJJEER	DRAWING TYPE:	ELEMENTARY DIAGRAM
ENGR:	S.ADONGO		
DATE:	NOVEMBER 11 2009		
DRAWING STATUS:	RECORD	DWG#	E2745251-006-07



REV	DESCRIPTION	BY	DATE																	
-	-	-	-	-	-	-	-	-	-	-	-	-	-	-	-	-	-	-	-	-

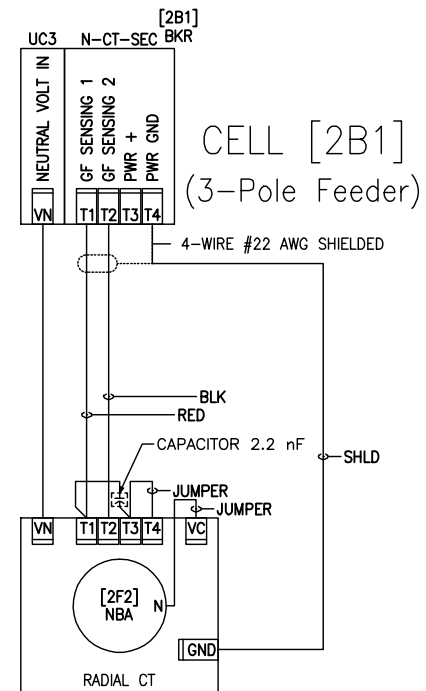

P/N: S48903 - 400/2000A CT (NW)

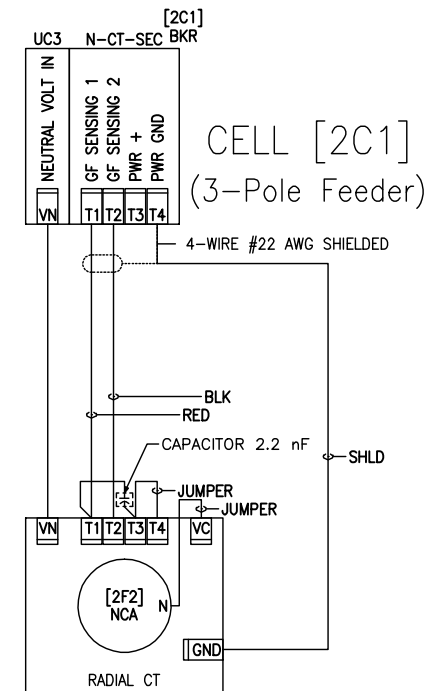

P/N: S48903 - 400/2000A CT (NW)

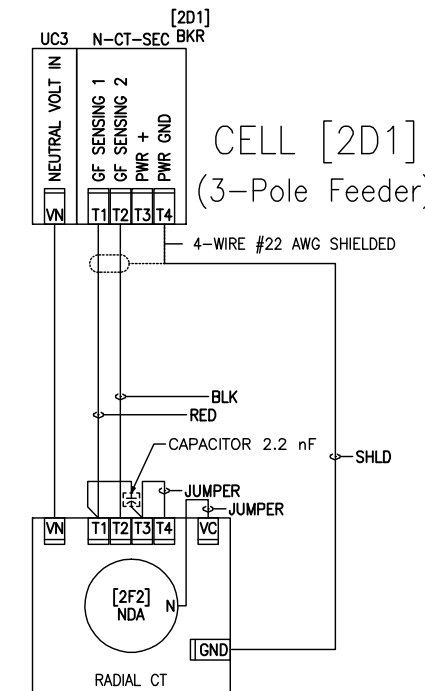

P/N: S48903 - 400/2000A CT (NW)

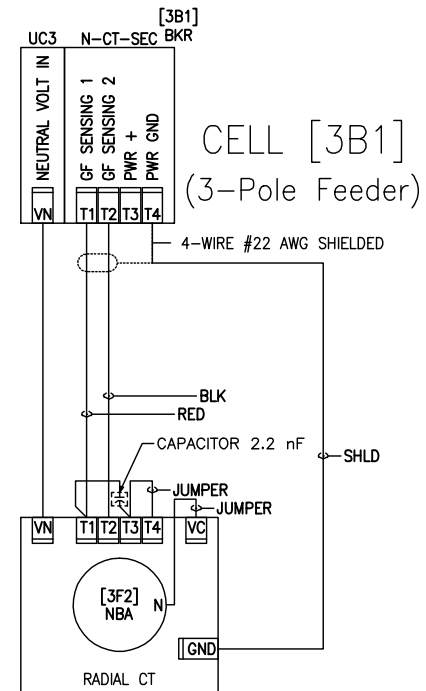

P/N: S48903 - 400/2000A CT (NW)

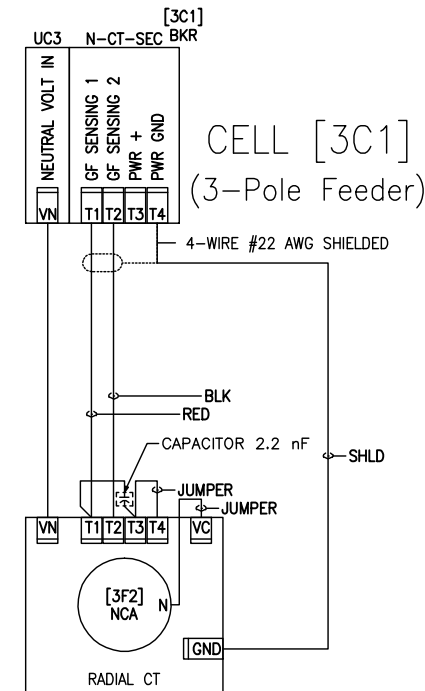

P/N: S48903 - 400/2000A CT (NW)

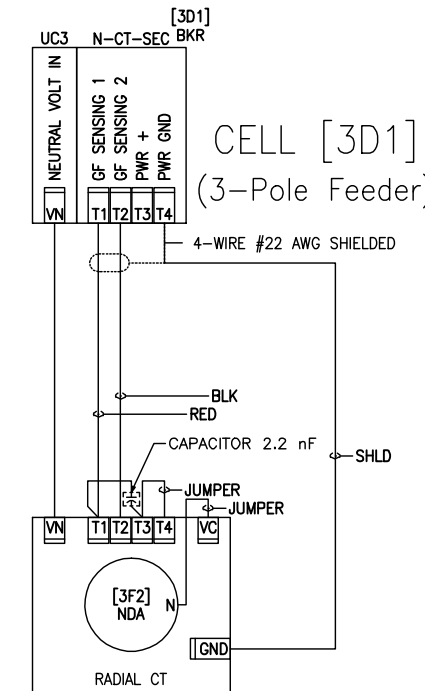

P/N: S48903 - 400/2000A CT (NW)

NW RADIAL GROUND FAULT

- NOTES:
1. ALL WIRING TO BE TYPE "SIS" (UL LISTED)
 2. USE #22 AWG SHIELDED WIRE UNLESS OTHERWISE NOTED.
 3. ALL SYMBOLS ARE SHOWN WITH CIRCUIT BREAKER OPEN, CONNECTED AND CHARGED.
 4. REMOVE THE FACTORY INSTALLED JUMPER BETWEEN T1 & T2 WHEN NEUTRAL CT IS CONNECTED.

JOB NAME:	JHU/APL SUBS 2 & 3 CONSOLIDATION	EQUIPMENT DESIGNATION:	SUBSTATION A
JOB LOCATION:	LAUREL MD	EQUIPMENT TYPE:	PZ4 SWITCHGEAR
DRAWN BY:	S.KUNDU/AJEER	DRAWING TYPE:	ELEMENTARY DIAGRAM
ENGR:	S.ADONGO		
DATE:	NOVEMBER 11 2009	by Schneider Electric	
DRAWING STATUS:	RECORD	DWG#	E27452521-006-07

REV	DESCRIPTION	BY	DATE						
-	-	-	-	-	-	-	-	-	-

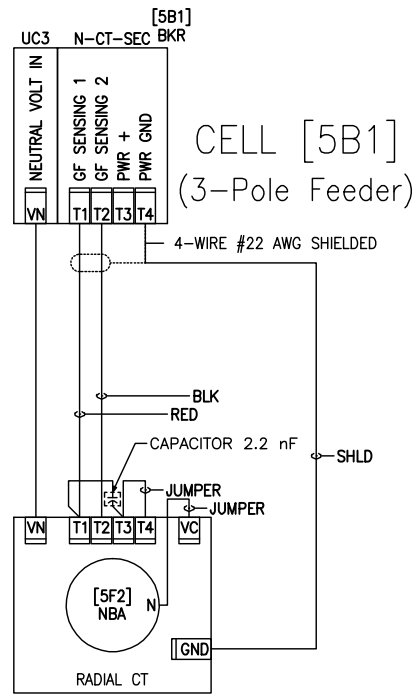

P/N: S48903 - 400/2000A CT (NW)

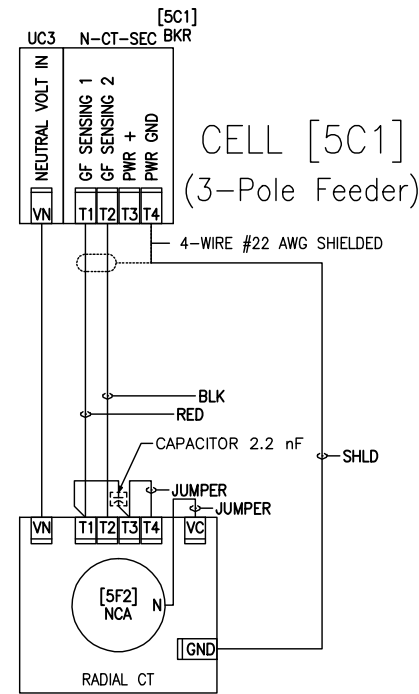

P/N: S48903 - 400/2000A CT (NW)

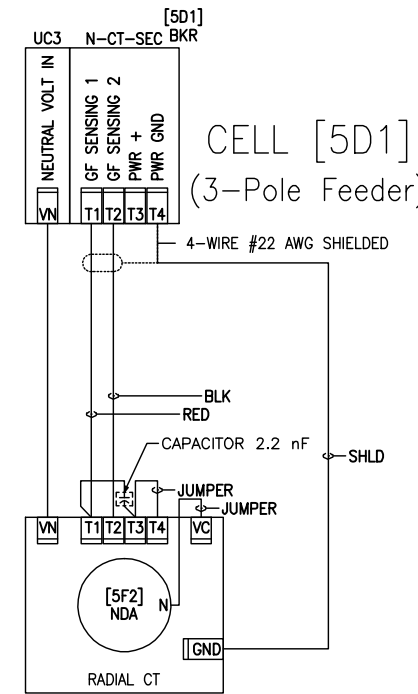

P/N: S48903 - 400/2000A CT (NW)

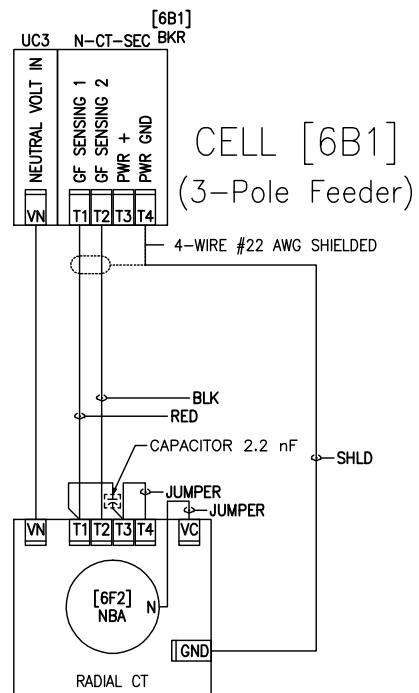

P/N: S48903 - 400/2000A CT (NW)

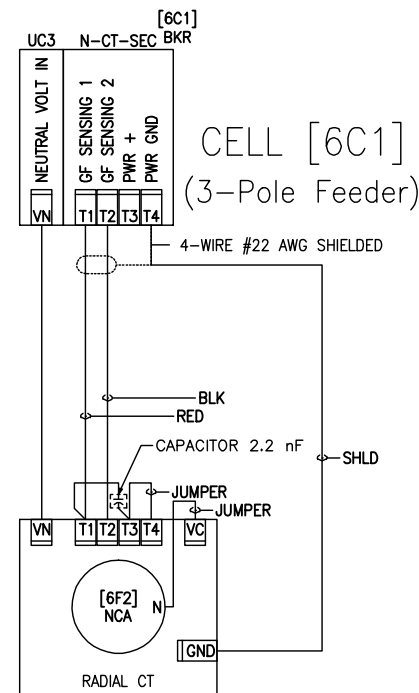

P/N: S48903 - 400/2000A CT (NW)

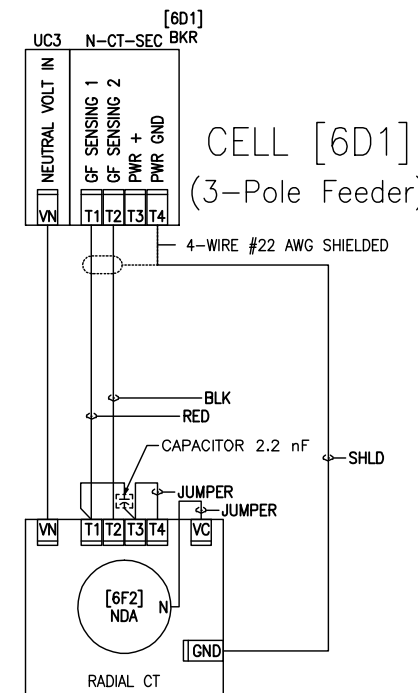

P/N: S48902 - 100/250A CT (NW)

NW RADIAL GROUND FAULT

- NOTES:
1. ALL WIRING TO BE TYPE "SIS" (UL LISTED)
 2. USE #22 AWG SHIELDED WIRE UNLESS OTHERWISE NOTED.
 3. ALL SYMBOLS ARE SHOWN WITH CIRCUIT BREAKER OPEN, CONNECTED AND CHARGED.
 4. REMOVE THE FACTORY INSTALLED JUMPER BETWEEN T1 & T2 WHEN NEUTRAL CT IS CONNECTED.

JOB NAME:	JHU/APL SUBS 2 & 3 CONSOLIDATION	EQUIPMENT DESIGNATION:	SUBSTATION A
JOB LOCATION:	LAUREL MD	EQUIPMENT TYPE:	PZ4 SWITCHGEAR
DRAWN BY:	S.KUNDU/AJEER	DRAWING TYPE:	ELEMENTARY DIAGRAM
ENGR:	S.ADONGO		
DATE:	NOVEMBER 11 2009	by Schneider Electric	
DRAWING STATUS:	RECORD	DWG#	E27452521-006-07

REV	DESCRIPTION	BY	DATE						
-	----	--	---/---/---	-	----	--	---/---/---	-	----

MAIN# 1

TIE

MAIN# 2

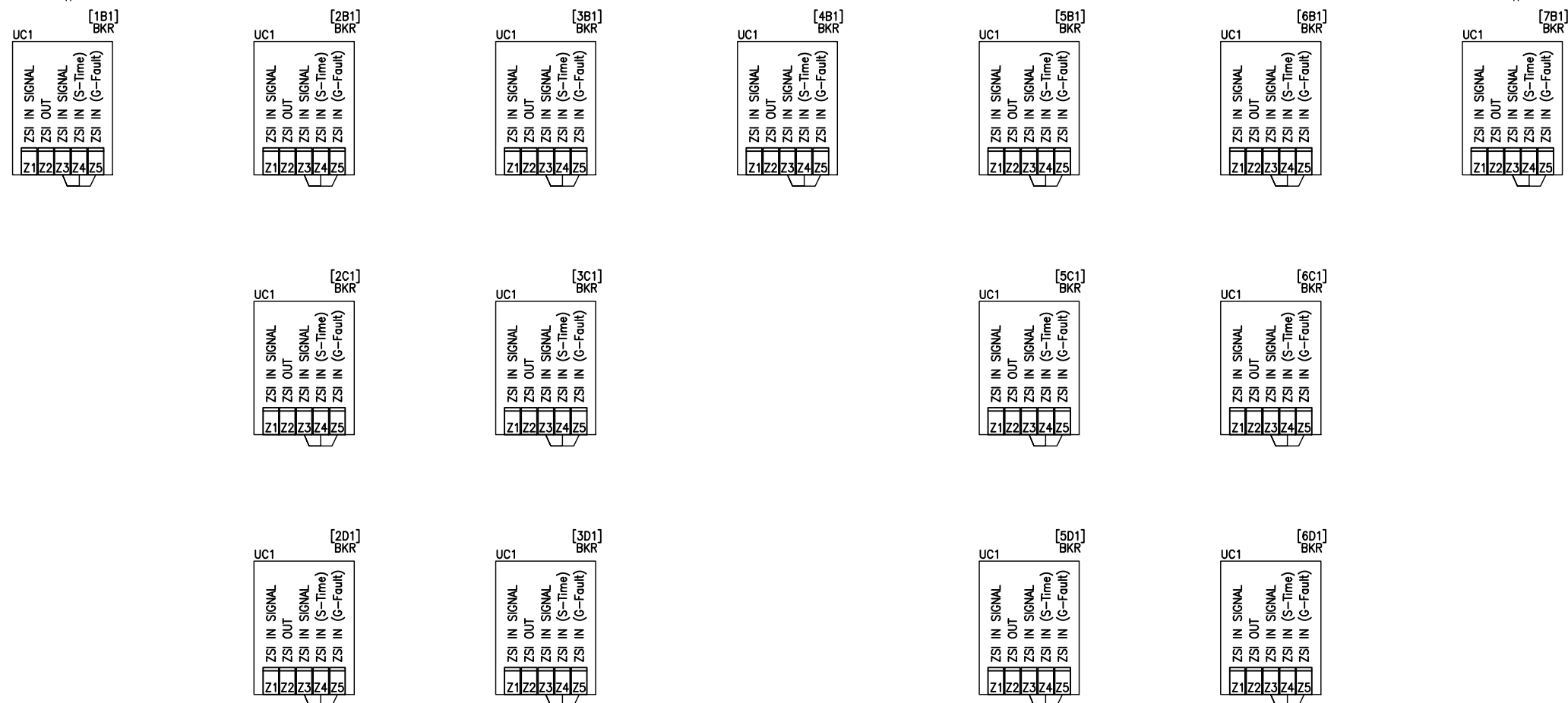

- NOTES:
 1. ALL WIRING TO BE TYPE "SIS" (UL LISTED)
 2. USE #22 AWG WIRE UNLESS OTHERWISE NOTED.

FACTORY JUMPERS (CIRCUIT BREAKER SELF RESTRAINTS)

JOB NAME:	JHU/APL SUBS 2 & 3 CONSOLIDATION	EQUIPMENT DESIGNATION:	SUBSTATION A
JOB LOCATION:	LAUREL MD	EQUIPMENT TYPE:	PZ4 SWITCHGEAR
DRAWN BY:	S.KUNDU/AJEER	DRAWING TYPE:	ELEMENTARY DIAGRAM
ENGR:	S.ADONGO		
DATE:	NOVEMBER 11 2009	by Schneider Electric	
DRAWING STATUS:	RECORD	DWG#	E27452521-006-08

REV	DESCRIPTION	BY	DATE						
-	-	-	-	-	-	-	-	-	-

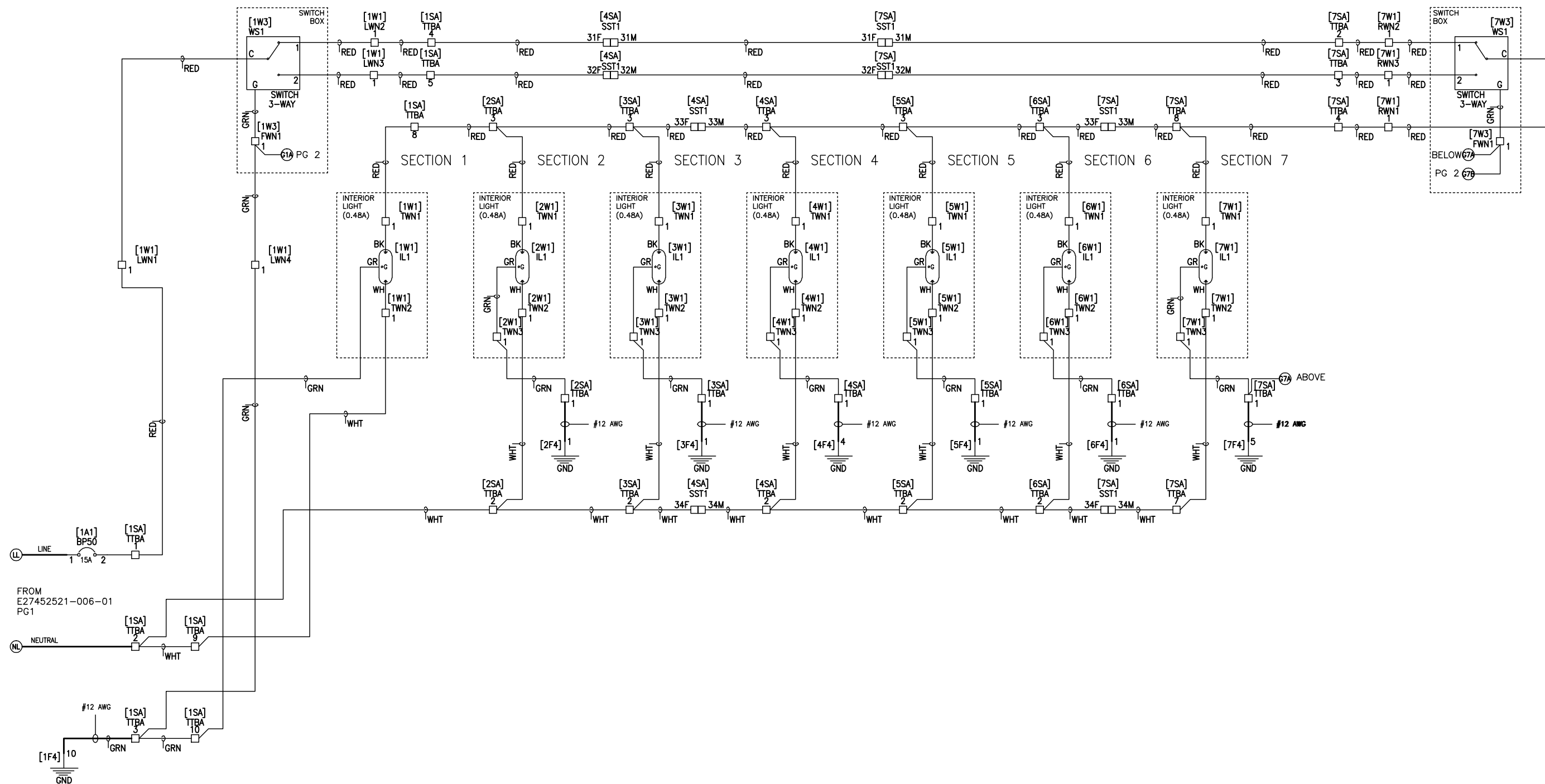

ALL WIRE IS #14AWG SIS EXCEPT WHERE NOTED

AISLE LIGHTING

JOB NAME:	JHU/APL SUBS 2 & 3 CONSOLIDATION	EQUIPMENT DESIGNATION:	SUBSTATION A
JOB LOCATION:	LAUREL MD	EQUIPMENT TYPE:	PZ4 SWITCHGEAR
DRAWN BY:	S.KUNDU/AJEER	DRAWING TYPE:	ELEMENTARY DIAGRAM
ENGR:	S.ADONGO		
DATE:	NOVEMBER 11 2009	by Schneider Electric	
DRAWING STATUS:	RECORD	DWG#	E27452521-006-09

REV	DESCRIPTION	BY	DATE						
-	----	--	---/---/---	-	----	--	---/---/---	-	----

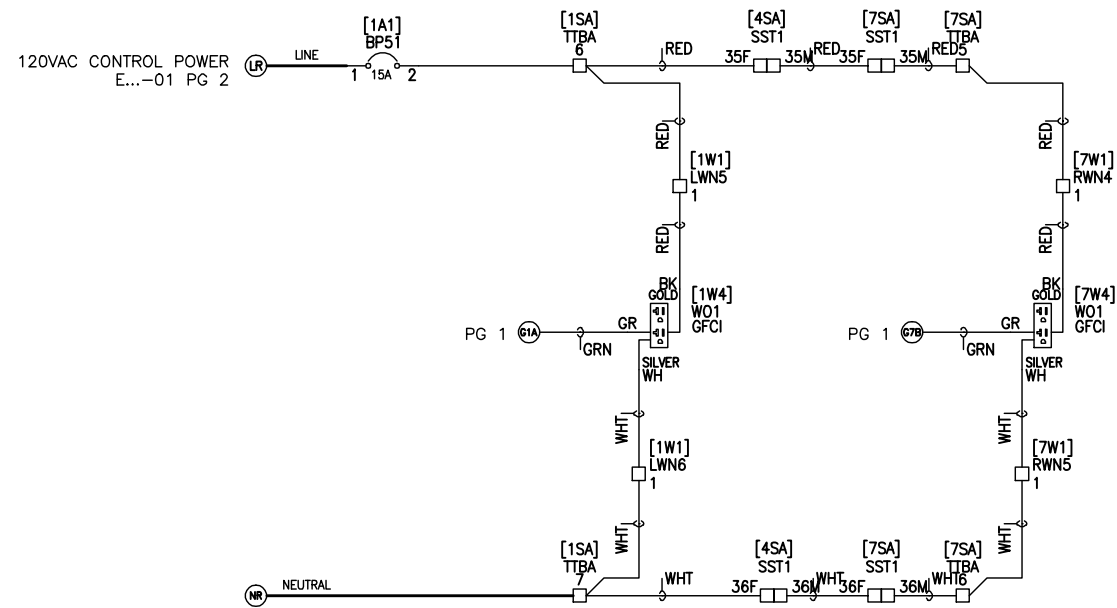

aisle RECEPTACLES

ALL WIRE IS #14AWG SIS EXCEPT WHERE NOTED

JOB NAME:	JHU/APL SUBS 2 & 3 CONSOLIDATION	EQUIPMENT DESIGNATION:	SUBSTATION A
JOB LOCATION:	LAUREL MD	EQUIPMENT TYPE:	PZ4 SWITCHGEAR
DRAWN BY:	S.KUNDU/AJEEER	DRAWING TYPE:	ELEMENTARY DIAGRAM
ENGR:	S.ADONGO		
DATE:	NOVEMBER 11 2009	by Schneider Electric	
DRAWING STATUS:	RECORD	DWG#	E27452521-006-09
		PG2	OF 2
		REV	-

REV	DESCRIPTION	BY	DATE	B	REVERSED X2/H2 ON X25 PT	SA	04/06/2010	-	----	--	--/--/--
A	REVERSED PT WIRING ON 7D AND XD1B ON 1A	SA	03/30/2010	-	----	--	--/--/--	-	----	--	--/--/--

CELL A INSTRUMENT COMPARTMENT

CELL 1A IC

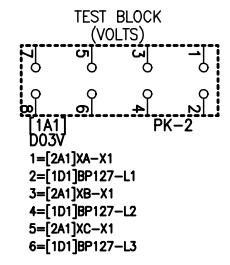
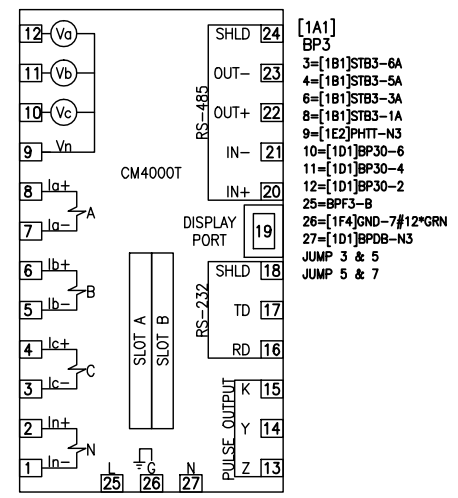

DOOR

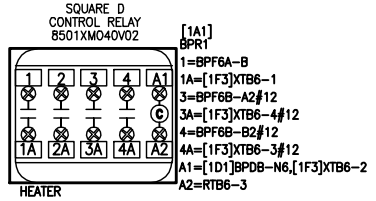

- NO COMPONENTS -

LEFT PAN

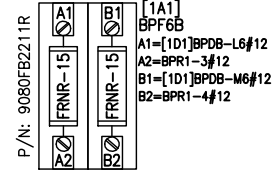
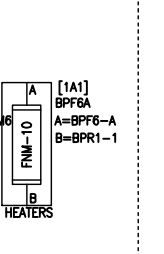
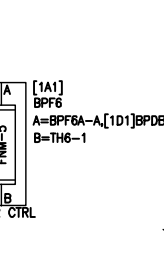
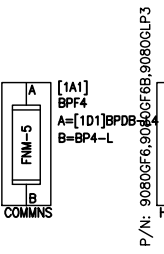
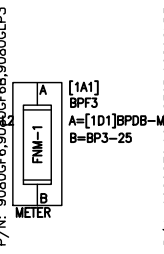
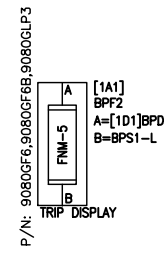
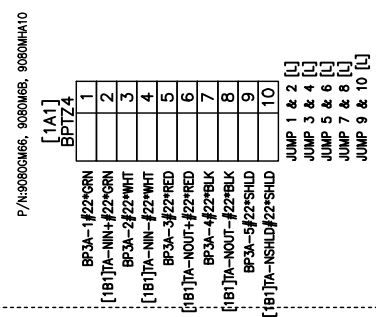
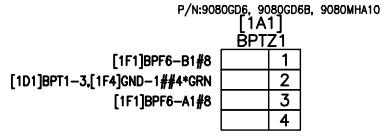
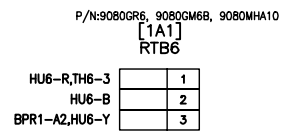
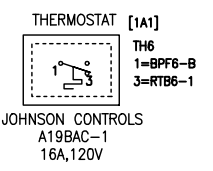
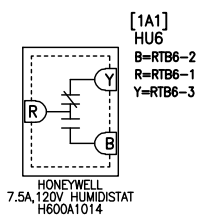
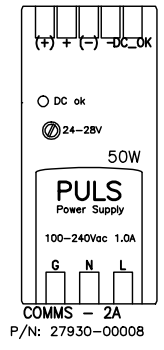
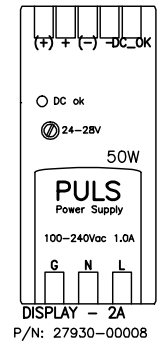
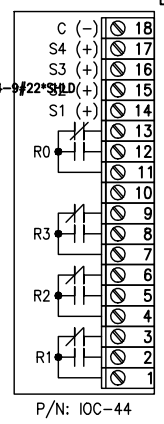
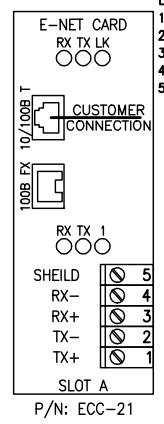
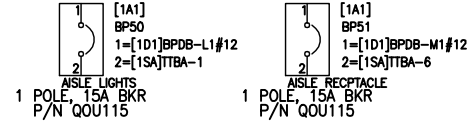

BACK PAN

RIGHT PAN

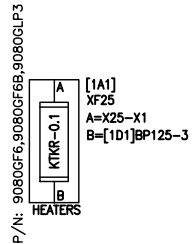
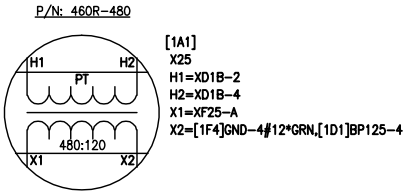
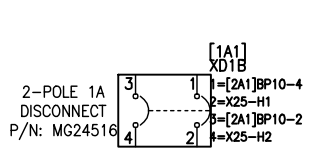

LEFT PAN

RIGHT PAN

BOTTOM PAN

- NOTES:
- ALL #22 AWG WIRE WITH A COLOR DESIGNATION (RED, BLK, WHT, GRN) IS 2466C 4-CONDUCTOR ALPHA CABLE (OR EQUIVALENT).
 - ALL WIRE DESIGNATIONS INCLUDING A COLOR (GRA, RED) PLUS A ONE OR TWO DIGIT NUMBER INDICATE A TWISTED PAIR. FOR EXAMPLE, GRA70 AND RED70 MAKE UP A SINGLE TWISTED PAIR WIRE.
 - ROUTE ALL SHIELDED CABLE AND TWISTED PAIR WIRE IN BOTTOM WIREWAY.

SECTION [1]

JOB NAME:	JHU/APL SUBS 2 & 3 CONSOLIDATION	EQUIPMENT DESIGNATION:	SUBSTATION A
JOB LOCATION:	LAUREL MD	EQUIPMENT TYPE:	PZ4 SWITCHGEAR
DRAWN BY:	A.JEER	DRAWING TYPE:	WIRING DIAGRAM
ENGR:	S.ADONGO		
DATE:	FEBRUARY 08, 2010		
DRAWING STATUS:	RECORD	DWG#	W27452521-006-01
		PG1	OF 3
		REV B	

REV	DESCRIPTION	BY	DATE	B	REVERSED X2/H2 ON X25 PT	SA	04/06/2010	-	----	--	--	--	--
A	REVERSED PT WIRING ON 7D AND XD1B ON 1A	SA	03/30/2010	C	UPDATED PT TERMINAL WIRING	SA	04/07/2010	-	----	--	--	--	--

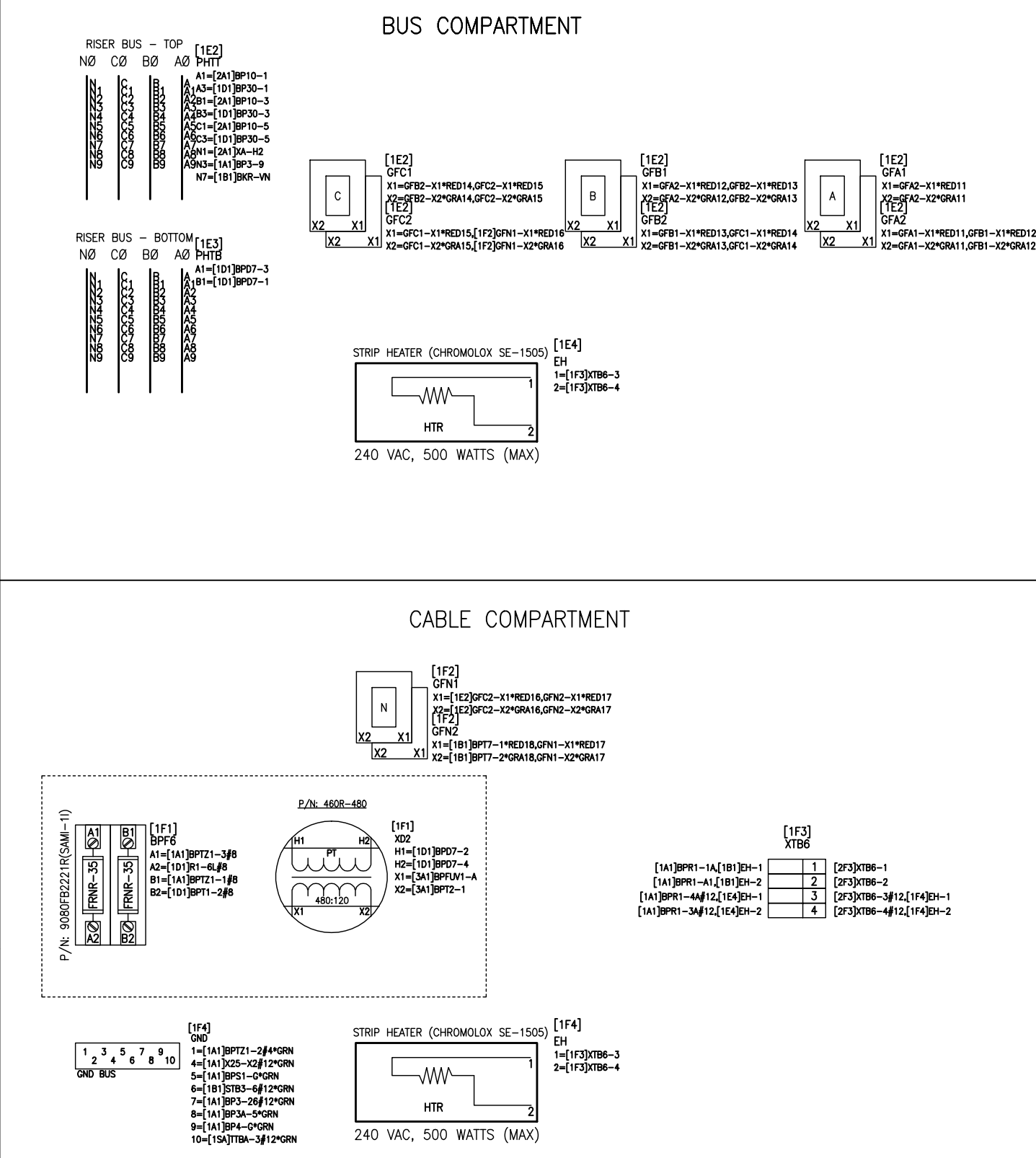
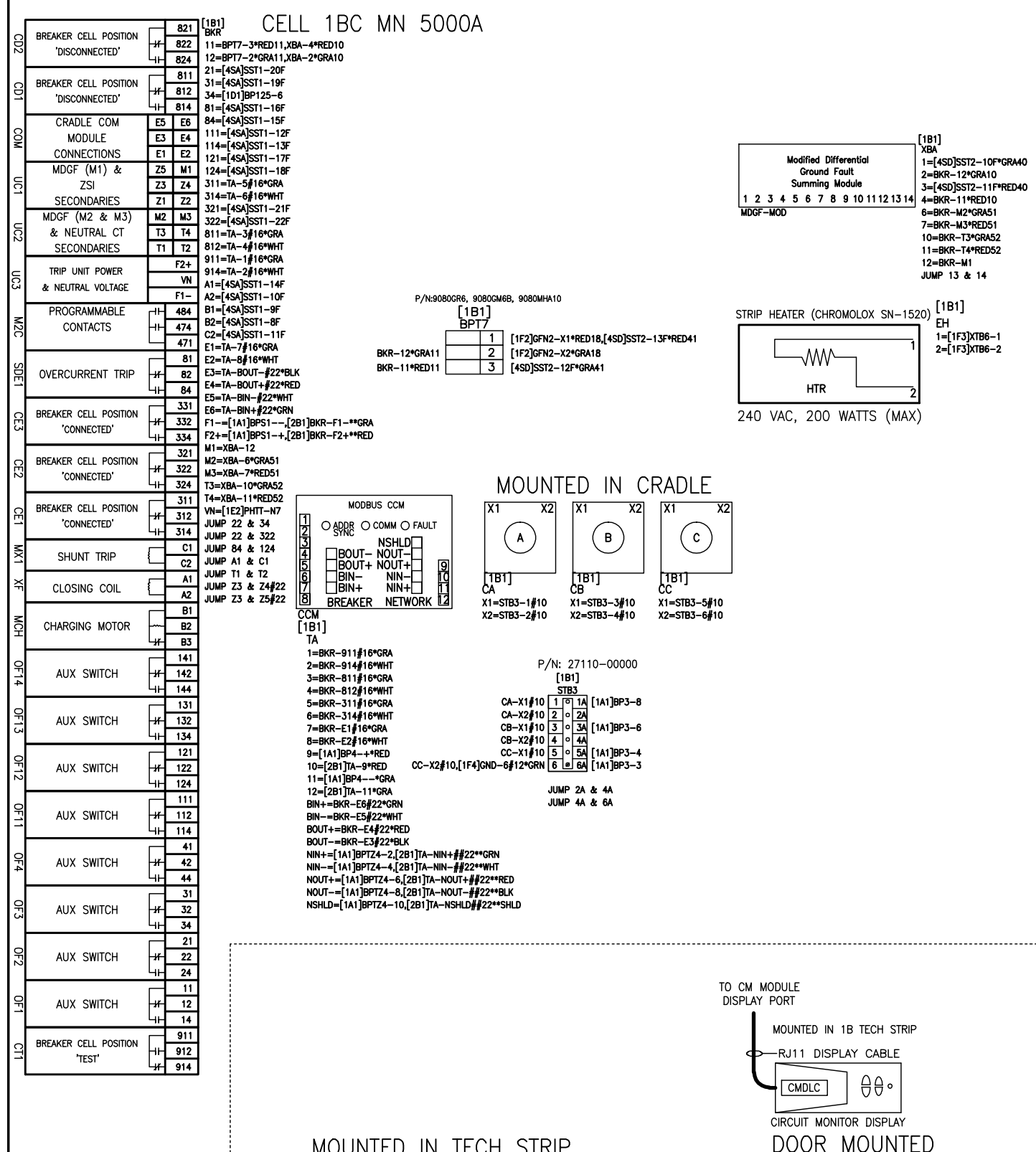

REV	DESCRIPTION	BY	DATE	B	UPDATED PT TERMINAL WIRING	SA	04/07/2010	-	----	--	--/--/--
A	REVERSED PT WIRING ON 7D AND XD1B ON 1A	SA	03/30/2010	-	----	--	--/--/--	-	----	--	--/--/--

CELL D INSTRUMENT COMPARTMENT

- NO COMPONENTS -

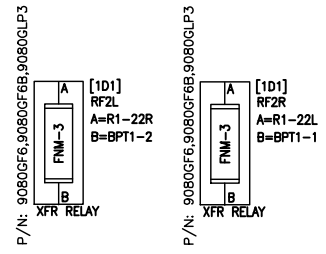
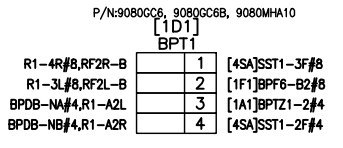
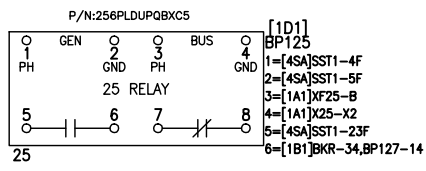
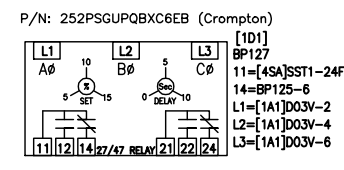
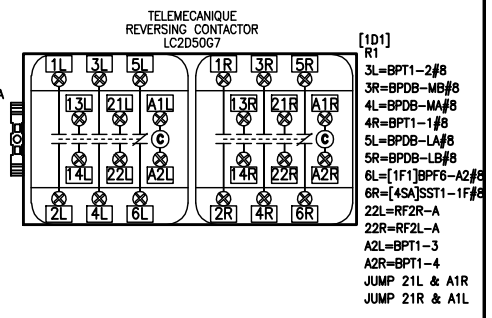
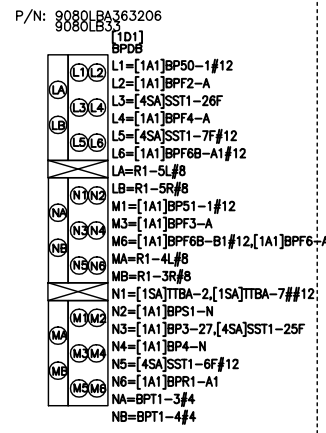
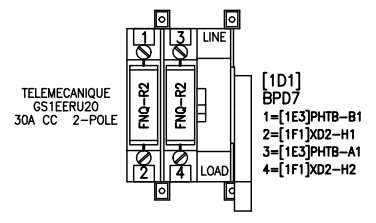
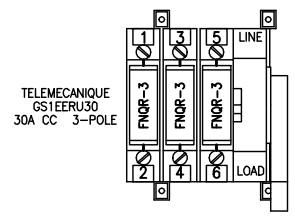

LEFT PAN

BACK PAN

RIGHT PAN

- NO COMPONENTS -

BOTTOM PAN

NOTES:
 1. ALL #22 AWG WIRE WITH A COLOR DESIGNATION (RED, BLK, WHT, GRN) IS 2466C 4-CONDUCTOR ALPHA CABLE (OR EQUIVALENT).
 2. ALL WIRE DESIGNATIONS INCLUDING A COLOR (GRA, RED) PLUS A ONE OR TWO DIGIT NUMBER INDICATE A TWISTED PAIR. FOR EXAMPLE, GRA70 AND RED70 MAKE UP A SINGLE TWISTED PAIR WIRE.
 3. ROUTE ALL SHIELDED CABLE AND TWISTED PAIR WIRE IN BOTTOM WIREWAY.

SECTION [1]

JOB NAME:	JHU/APL SUBS 2 & 3 CONSOLIDATION	EQUIPMENT DESIGNATION:	SUBSTATION A
JOB LOCATION:	LAUREL MD	EQUIPMENT TYPE:	PZ4 SWITCHGEAR
DRAWN BY:	A.JEER	DRAWING TYPE:	WIRING DIAGRAM
ENGR:	S.ADONGO		
DATE:	FEBRUARY 08, 2010	DWG#	W27452521-006-01
DRAWING STATUS:	RECORD	PG	3 OF 3
			REV

REV	DESCRIPTION	BY	DATE																		
---	----	---	----	---	----	---	----	---	----	---	----	---	----	---	----	---	----	---	----	---	----

CELL 2A IC

CELL 2B NW 2000A

CELL 2C NW(PS) 2000A

CELL 2D NW(PS) 2000A

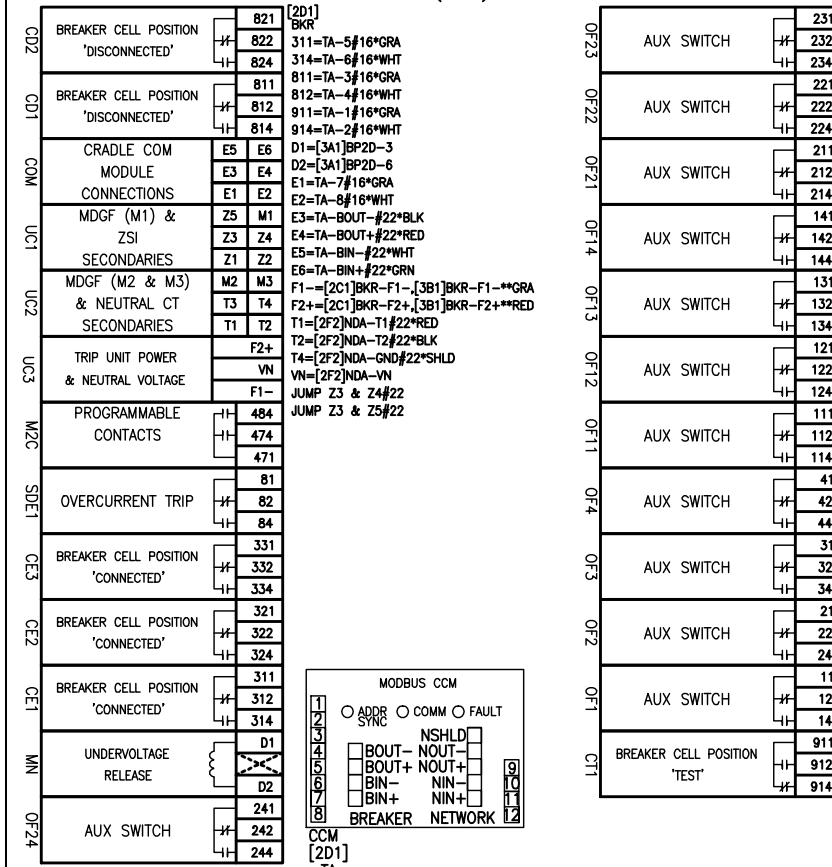
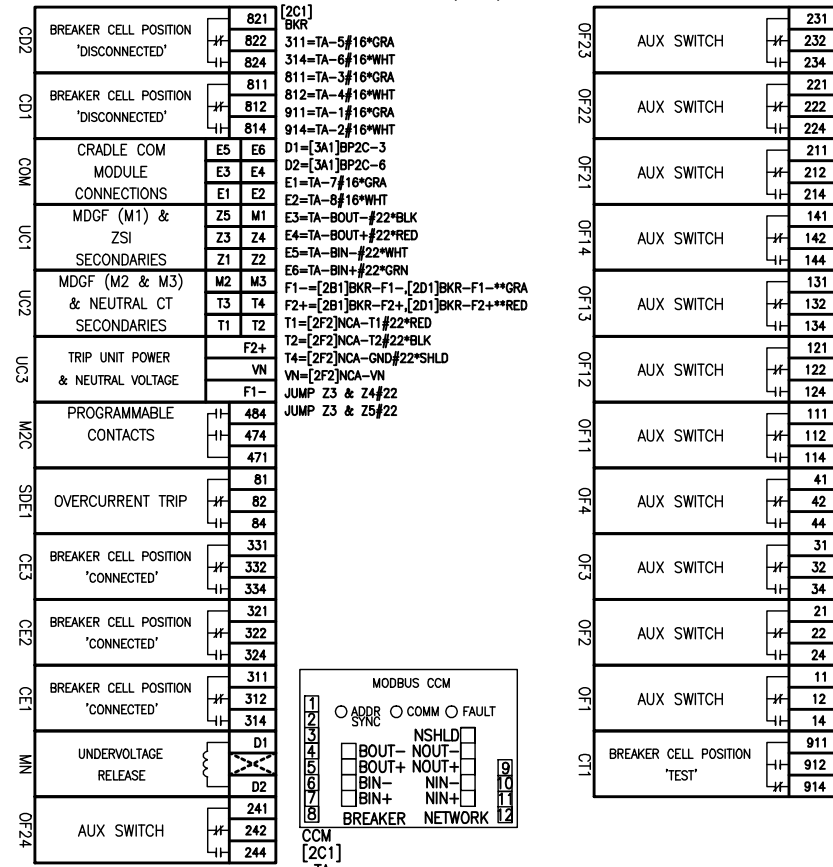
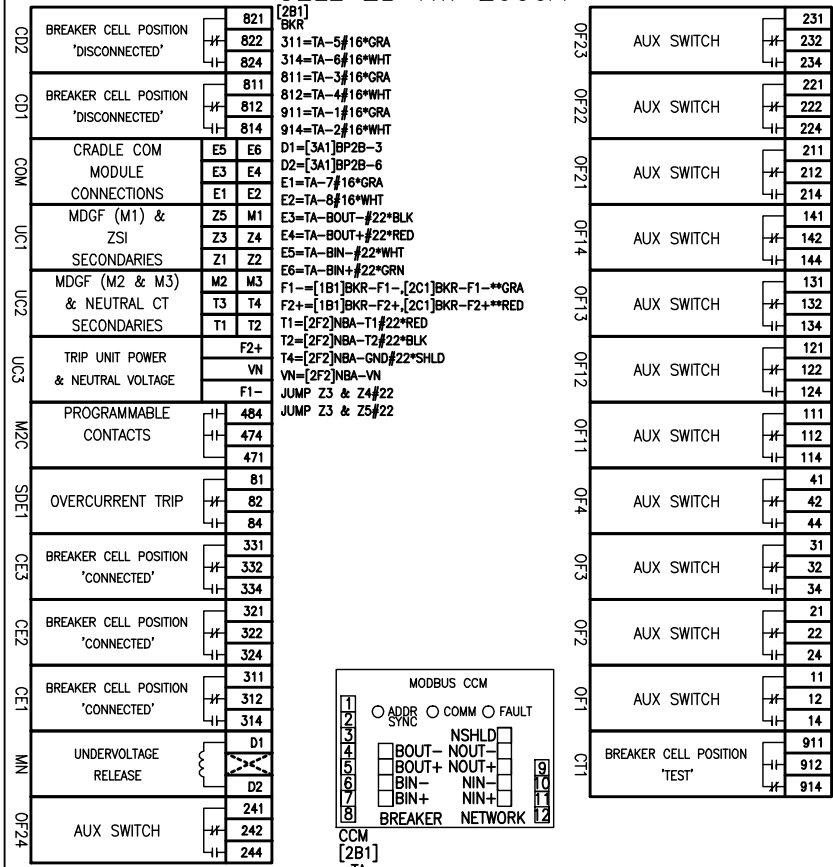

- MODBUS CCM
- ADDR COMM FAULT
 NSHLD
 BOUT- NOUT-
 BOUT+ NOUT+
 BIN- NIN-
 BIN+ NIN+
 BREAKER NETWORK
- CCM [2B1]
- TA
- 1=BKR-911#16*GRA
 - 2=BKR-914#16*WHT
 - 3=BKR-811#16*GRA
 - 4=BKR-812#16*WHT
 - 5=BKR-311#16*GRA
 - 6=BKR-314#16*WHT
 - 7=BKR-E1#16*GRA
 - 8=BKR-E2#16*WHT
 - 9=[1B1]TA-10*RED
 - 10=[2C1]TA-9*RED
 - 11=[1B1]TA-12*GRA
 - 12=[2C1]TA-11*GRA
 - BIN+=BKR-E6#22*GRN
 - BIN-=BKR-E5#22*WHT
 - BOUT+=BKR-E4#22*RED
 - BOUT-=BKR-E3#22*BLK
 - NIN+= [1B1]TA-NIN+,[2C1]TA-NIN+##22*GRN
 - NIN-= [1B1]TA-NIN-,[2C1]TA-NIN-##22*WHT
 - NOUT+= [1B1]TA-NOUT+,[2C1]TA-NOUT+##22*RED
 - NOUT-= [1B1]TA-NOUT-,[2C1]TA-NOUT-##22*BLK
 - NSHLD=[1B1]TA-NSHLD,[2C1]TA-NSHLD##22*SHLD

- MODBUS CCM
- ADDR COMM FAULT
 NSHLD
 BOUT- NOUT-
 BOUT+ NOUT+
 BIN- NIN-
 BIN+ NIN+
 BREAKER NETWORK
- CCM [2C1]
- TA
- 1=BKR-911#16*GRA
 - 2=BKR-914#16*WHT
 - 3=BKR-811#16*GRA
 - 4=BKR-812#16*WHT
 - 5=BKR-311#16*GRA
 - 6=BKR-314#16*WHT
 - 7=BKR-E1#16*GRA
 - 8=BKR-E2#16*WHT
 - 9=[2B1]TA-10*RED
 - 10=[2D1]TA-9*RED
 - 11=[2B1]TA-12*GRA
 - 12=[2D1]TA-11*GRA
 - BIN+=BKR-E6#22*GRN
 - BIN-=BKR-E5#22*WHT
 - BOUT+=BKR-E4#22*RED
 - BOUT-=BKR-E3#22*BLK
 - NIN+= [2B1]TA-NIN+,[2D1]TA-NIN+##22*GRN
 - NIN-= [2B1]TA-NIN-,[2D1]TA-NIN-##22*WHT
 - NOUT+= [2B1]TA-NOUT+,[2D1]TA-NOUT+##22*RED
 - NOUT-= [2B1]TA-NOUT-,[2D1]TA-NOUT-##22*BLK
 - NSHLD=[2B1]TA-NSHLD,[2D1]TA-NSHLD##22*SHLD

- MODBUS CCM
- ADDR COMM FAULT
 NSHLD
 BOUT- NOUT-
 BOUT+ NOUT+
 BIN- NIN-
 BIN+ NIN+
 BREAKER NETWORK
- CCM [2D1]
- TA
- 1=BKR-911#16*GRA
 - 2=BKR-914#16*WHT
 - 3=BKR-811#16*GRA
 - 4=BKR-812#16*WHT
 - 5=BKR-311#16*GRA
 - 6=BKR-314#16*WHT
 - 7=BKR-E1#16*GRA
 - 8=BKR-E2#16*WHT
 - 9=[2C1]TA-10*RED
 - 10=[3B1]TA-9*RED
 - 11=[2C1]TA-12*GRA
 - 12=[3B1]TA-11*GRA
 - BIN+=BKR-E6#22*GRN
 - BIN-=BKR-E5#22*WHT
 - BOUT+=BKR-E4#22*RED
 - BOUT-=BKR-E3#22*BLK
 - NIN+= [2C1]TA-NIN+,[3B1]TA-NIN+##22*GRN
 - NIN-= [2C1]TA-NIN-,[3B1]TA-NIN-##22*WHT
 - NOUT+= [2C1]TA-NOUT+,[3B1]TA-NOUT+##22*RED
 - NOUT-= [2C1]TA-NOUT-,[3B1]TA-NOUT-##22*BLK
 - NSHLD=[2C1]TA-NSHLD,[3B1]TA-NSHLD##22*SHLD

MOUNTED IN TECH STRIP

MOUNTED IN TECH STRIP

MOUNTED IN TECH STRIP

- NOTES:
- ALL #22 AWG WIRE WITH A COLOR DESIGNATION (RED, BLK, WHT, GRN) IS 2466C 4-CONDUCTOR ALPHA CABLE (OR EQUIVALENT).
 - ALL WIRE DESIGNATIONS INCLUDING A COLOR (GRA, RED) PLUS A ONE OR TWO DIGIT NUMBER INDICATE A TWISTED PAIR. FOR EXAMPLE, GRA70 AND RED70 MAKE UP A SINGLE TWISTED PAIR WIRE.
 - ROUTE ALL SHIELDED CABLE AND TWISTED PAIR WIRE IN BOTTOM WIREWAY.

SECTION [2]

JOB NAME:	JHU/APL SUBS 2 & 3 CONSOLIDATION	EQUIPMENT DESIGNATION:	SUBSTATION A
JOB LOCATION:	LAUREL MD	EQUIPMENT TYPE:	PZ4 SWITCHGEAR
DRAWN BY:	A.JEER	DRAWING TYPE:	WIRING DIAGRAM
ENGR:	S.ADONGO		
DATE:	FEBRUARY 08, 2010		
DRAWING STATUS:	RECORD	DWG#	W2745251-006-02
		PG1	OF2
		REV	

REV	DESCRIPTION	BY	DATE	B	UPDATED PT TERMINAL WIRING	SA	04/07/2010	-	----	--	--/--/--
A	REVERSED PT WIRING ON 7D AND XD1B ON 1A	SA	03/30/2010	-	----	--	--/--/--	-	----	--	--/--/--

CELL 2A IC

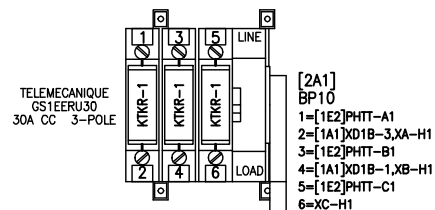

CELL 2B NW 2000A

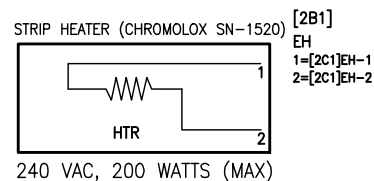
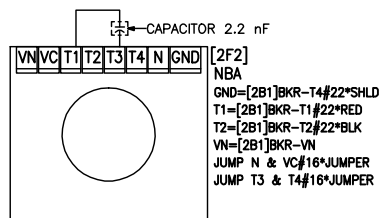

CELL 2C NW(PS) 2000A

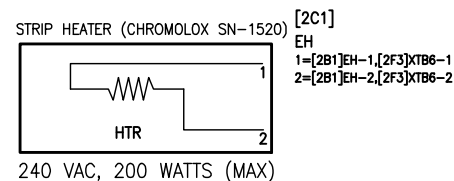
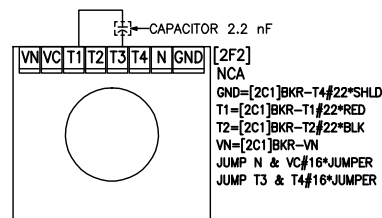

CELL 2D NW(PS) 2000A

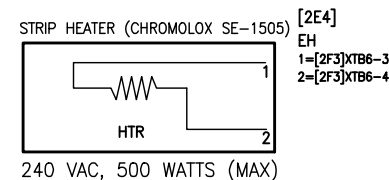
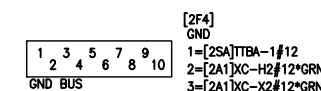
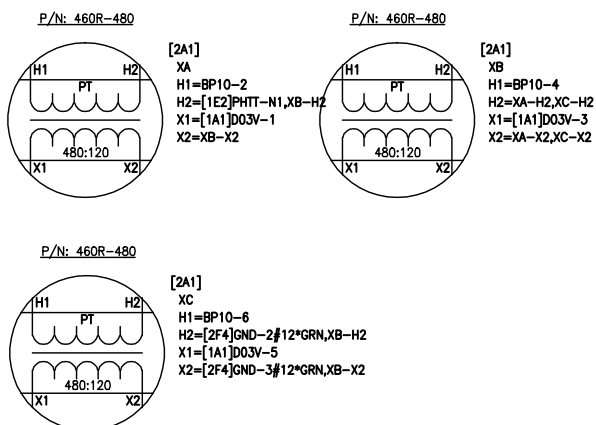
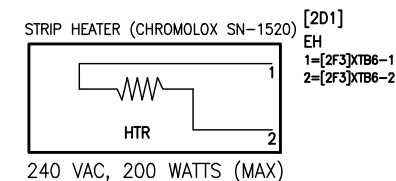
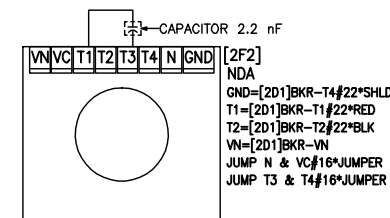

[2F3] XTB6	1	[2D1]EH-1, [3F3]XTB6-1
[1F3]XTB6-1, [2C1]EH-1	2	[2D1]EH-2, [3F3]XTB6-2
[1F3]XTB6-2, [2C1]EH-2	3	[3F3]XTB6-3#12, [2F4]EH-1
[1F3]XTB6-3#12, [2E4]EH-2	4	[3F3]XTB6-4#12, [2F4]EH-2

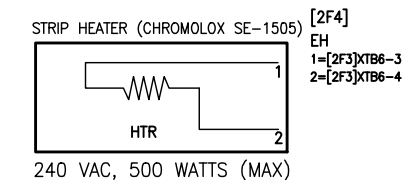

BUS COMPARTMENT

CABLE COMPARTMENT

- NOTES:
- ALL #22 AWG WIRE WITH A COLOR DESIGNATION (RED, BLK, WHT, GRN) IS 2466C 4-CONDUCTOR ALPHA CABLE (OR EQUIVALENT).
 - ALL WIRE DESIGNATIONS INCLUDING A COLOR (GRA, RED) PLUS A ONE OR TWO DIGIT NUMBER INDICATE A TWISTED PAIR. FOR EXAMPLE, GRA70 AND RED70 MAKE UP A SINGLE TWISTED PAIR WIRE.
 - ROUTE ALL SHIELDED CABLE AND TWISTED PAIR WIRE IN BOTTOM WIREWAY.

SECTION [2]

JOB NAME:	JHU/APL SUBS 2 & 3 CONSOLIDATION	EQUIPMENT DESIGNATION:	SUBSTATION A
JOB LOCATION:	LAUREL MD	EQUIPMENT TYPE:	PZ4 SWITCHGEAR
DRAWN BY:	A.JEER	DRAWING TYPE:	WIRING DIAGRAM
ENGR:	S.ADONGO		
DATE:	FEBRUARY 08, 2010		
DRAWING STATUS:	RECORD	DWG#	W2745251-006-02



REV	DESCRIPTION	BY	DATE																		
---	---	---	---	---	---	---	---	---	---	---	---	---	---	---	---	---	---	---	---	---	---

CELL 3A IC

CELL 3B NW 2000A

CELL 3C NW 2000A

CELL 3D NW(PS) 2000A

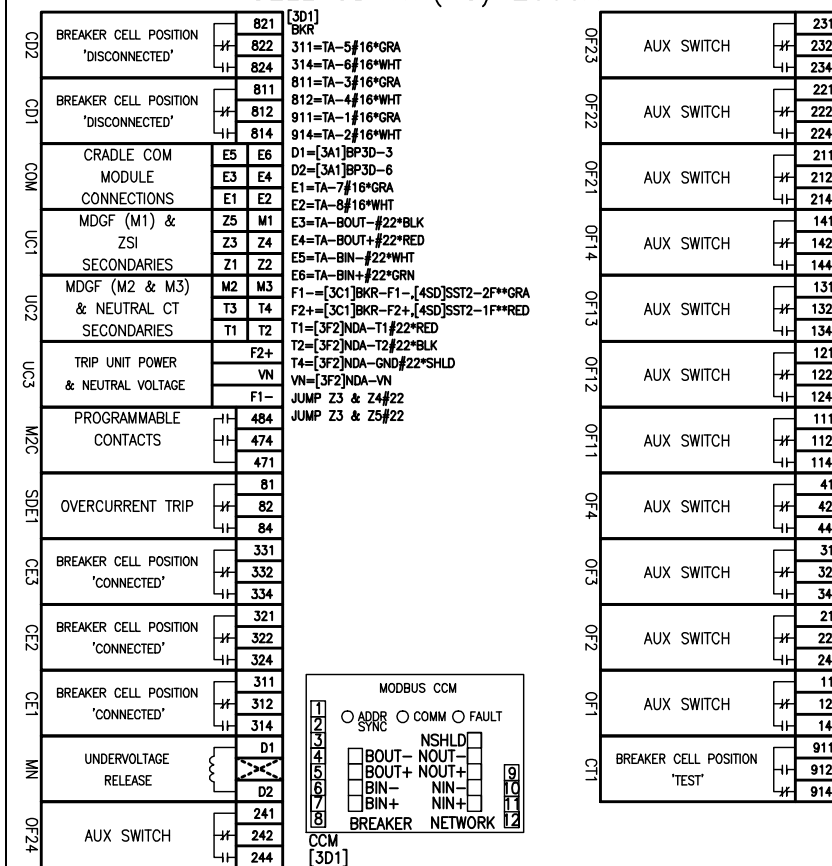
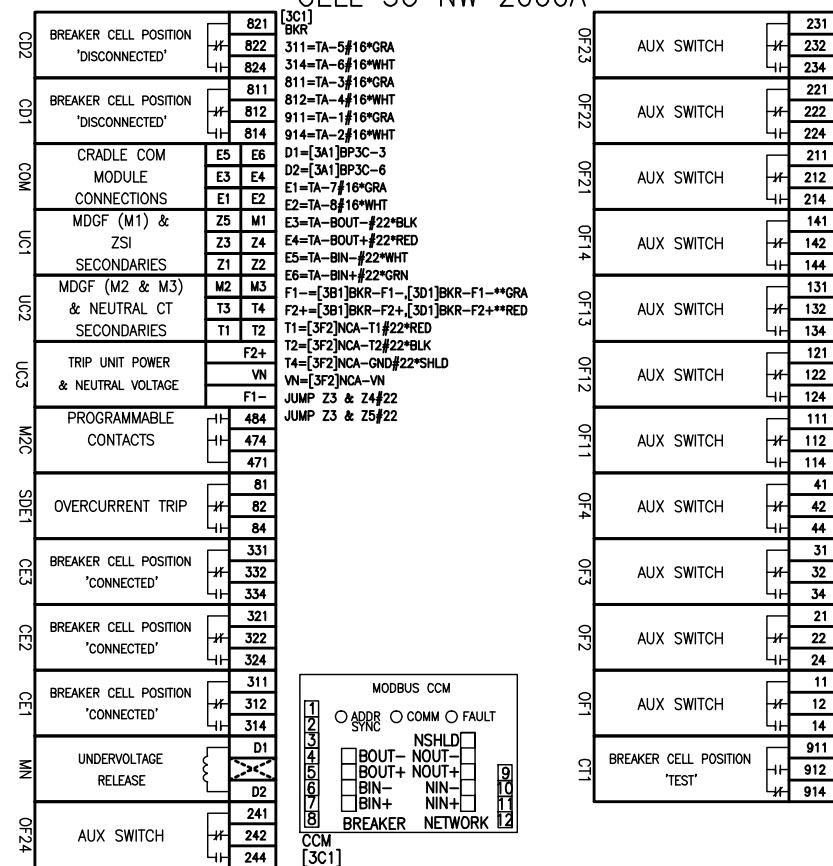
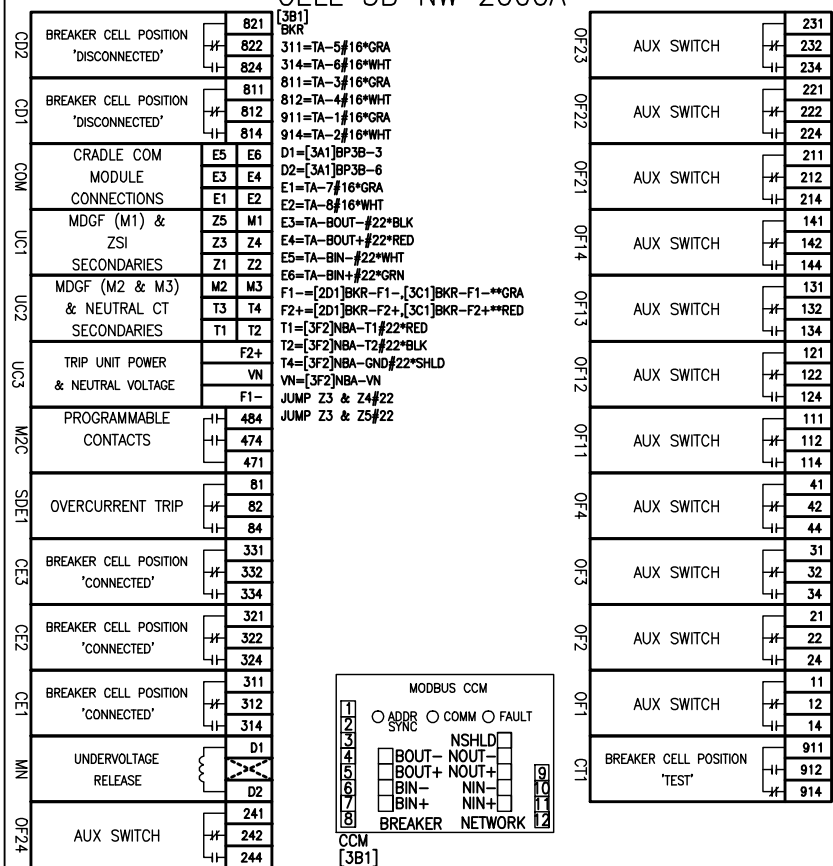

MOUNTED IN TECH STRIP

MOUNTED IN TECH STRIP

MOUNTED IN TECH STRIP

- NOTES:
- ALL #22 AWG WIRE WITH A COLOR DESIGNATION (RED, BLK, WHT, GRN) IS 2466C 4-CONDUCTOR ALPHA CABLE (OR EQUIVALENT).
 - ALL WIRE DESIGNATIONS INCLUDING A COLOR (GRA, RED) PLUS A ONE OR TWO DIGIT NUMBER INDICATE A TWISTED PAIR. FOR EXAMPLE, GRA70 AND RED70 MAKE UP A SINGLE TWISTED PAIR WIRE.
 - ROUTE ALL SHIELDED CABLE AND TWISTED PAIR WIRE IN BOTTOM WIREWAY.

SECTION [3]

JOB NAME:	JHU/APL SUBS 2 & 3 CONSOLIDATION	EQUIPMENT DESIGNATION:	SUBSTATION A
JOB LOCATION:	LAUREL MD	EQUIPMENT TYPE:	PZ4 SWITCHGEAR
DRAWN BY:	A.JEER	DRAWING TYPE:	WIRING DIAGRAM
ENGR:	S.ADONGO		
DATE:	FEBRUARY 08, 2010		
DRAWING STATUS:	RECORD	DWG#	W2745251-006-03
		PG1	OF 3
		REV	---

REV	DESCRIPTION	BY	DATE								
-											

CELL 3A IC

CELL 3B NW(PS) 2000A

CELL 3C NW(PS) 2000A

CELL 3D NW(PS) 2000A

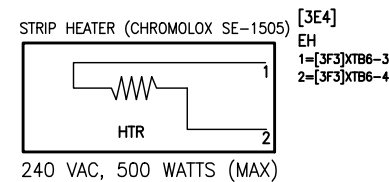
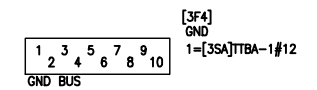
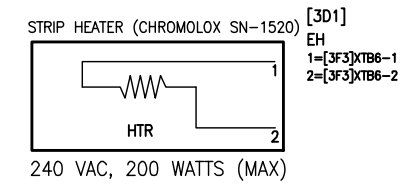
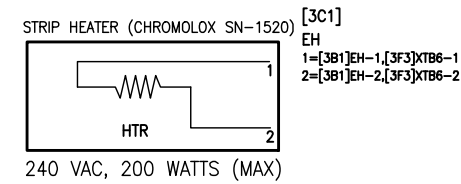
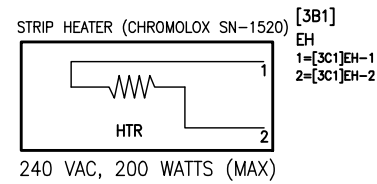
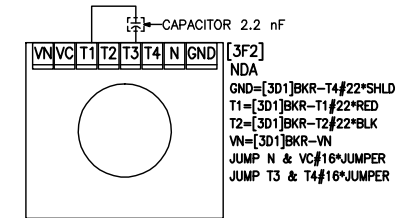
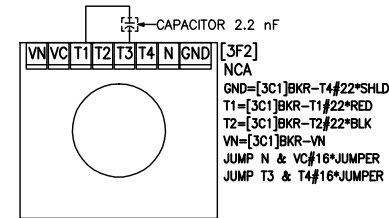
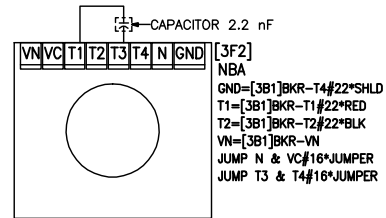

[2F3]XTB6-1,[3C1]EH-1	1	[3D1]EH-1,[4SA]SST1-27F
[2F3]XTB6-2,[3C1]EH-2	2	[3D1]EH-2,[4SA]SST1-29F
[2F3]XTB6-3#12,[3E4]EH-1	3	[4SA]SST1-29F#12,[3F4]EH-1
[2F3]XTB6-4#12,[3E4]EH-2	4	[4SA]SST1-30F#12,[3F4]EH-2

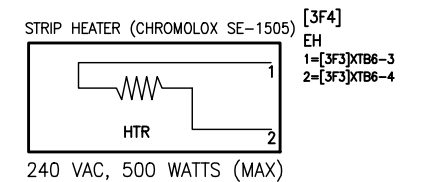

BUS COMPARTMENT

BUS COMPARTMENT

CABLE COMPARTMENT

- NOTES:
- ALL #22 AWG WIRE WITH A COLOR DESIGNATION (RED, BLK, WHT, GRN) IS 2466C 4-CONDUCTOR ALPHA CABLE (OR EQUIVALENT).
 - ALL WIRE DESIGNATIONS INCLUDING A COLOR (GRA, RED) PLUS A ONE OR TWO DIGIT NUMBER INDICATE A TWISTED PAIR. FOR EXAMPLE, GRA70 AND RED70 MAKE UP A SINGLE TWISTED PAIR WIRE.
 - ROUTE ALL SHIELDED CABLE AND TWISTED PAIR WIRE IN BOTTOM WIREWAY.

SECTION [3]

JOB NAME:	JHU/APL SUBS 2 & 3 CONSOLIDATION	EQUIPMENT DESIGNATION:	STATION A
JOB LOCATION:	LAUREL MD	EQUIPMENT TYPE:	PZ4 SWITCHGEAR
DRAWN BY:	A.JEER	DRAWING TYPE:	WIRING DIAGRAM
ENGR:	S.ADONGO		
DATE:	FEBRUARY 08, 2010	by Schneider Electric	
DRAWING STATUS:	RECORD	DWG#	W27452521-006-03
		PG2	OF 3
		REV	-

REV	DESCRIPTION	BY	DATE	B	UPDATED PT TERMINAL WIRING	SA	04/07/2010	-	----	--	--/--/--
A	REVERSED PT WIRING ON 7D AND XD1B ON 1A	SA	03/30/2010	-	----	--	--/--/--	-	----	--	--/--/--

CELL A INSTRUMENT COMPARTMENT

- NO COMPONENTS -

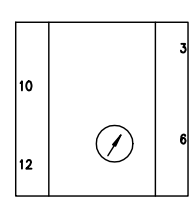

P/N: 33681

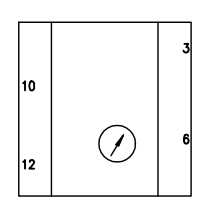

P/N: 33681

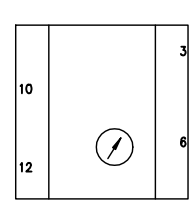
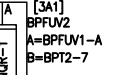
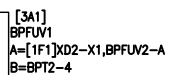
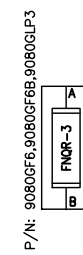

P/N: 33681

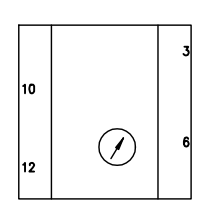

P/N: 33681

P/N: 9080GR6, 9080GM6B, 9080MHA10

[3A1] BPT2	1	[1F1]XD2-X2
BP2B-12	2	
BP2C-12, BP2D-12	3	
BP2B-10, BPFUV1-B	4	
BP2C-10, BP2D-10	5	
BP3B-12	6	
BP3B-10, BPFUV2-B	7	
BP3C-12, BP3D-12	8	
BP3C-10, BP3D-10	9	

- JUMP 1 & 2 [L]
- JUMP 1 & 6 [L]
- JUMP 2 & 3 [R]
- JUMP 4 & 5 [R]
- JUMP 6 & 8 [R]
- JUMP 7 & 9 [R]

- NO COMPONENTS -

LEFT PAN

BACK PAN

RIGHT PAN

- NO COMPONENTS -

BOTTOM PAN

- NOTES:
- ALL #22 AWG WIRE WITH A COLOR DESIGNATION (RED, BLK, WHT, GRN) IS 2466C 4-CONDUCTOR ALPHA CABLE (OR EQUIVALENT).
 - ALL WIRE DESIGNATIONS INCLUDING A COLOR (GRA, RED) PLUS A ONE OR TWO DIGIT NUMBER INDICATE A TWISTED PAIR. FOR EXAMPLE, GRA70 AND RED70 MAKE UP A SINGLE TWISTED PAIR WIRE.
 - ROUTE ALL SHIELDED CABLE AND TWISTED PAIR WIRE IN BOTTOM WIREWAY.

SECTION [3]

JOB NAME:	JHU/APL SUBS 2 & 3 CONSOLIDATION	EQUIPMENT DESIGNATION:	SUBSTATION A
JOB LOCATION:	LAUREL MD	EQUIPMENT TYPE:	PZ4 SWITCHGEAR
DRAWN BY:	A.JEER	DRAWING TYPE:	WIRING DIAGRAM
ENGR:	S.ADONGO		
DATE:	FEBRUARY 08, 2010	by Schneider Electric	
DRAWING STATUS:	RECORD	DWG#	W27452521-006-03
		PG	3 OF 3
		REV	B

REV	DESCRIPTION	BY	DATE										
-	-	-	-	-	-	-	-	-	-	-	-	-	-

CELL 4A IC

CELL 4BC TIE 5000A

CELL 4D IC

CD2	BREAKER CELL POSITION 'DISCONNECTED'	821 822 824	[4B1] BKR 11=XBA-4*RED20,[4SD]SST2-13M*RED43 12=XBA-2*GRA20,[4SD]SST2-12M*GRA43 21=[4A1]BPTC-2
CD1	BREAKER CELL POSITION 'DISCONNECTED'	811 812 814	31=[4A1]BPTC-1 81=[4A1]BPR14-13 84=[4SA]SST1-15M
COM	CRADLE COM MODULE CONNECTIONS	E5 E6 E3 E4 E1 E2	111=[4A1]BPR14-6,[4SA]SST1-13M 114=[4A1]BPR14-10 311=TA-5#16*GRA 314=TA-6#16*WHT
UC1	MDGF (M1) & ZSI	Z5 M1 Z3 Z4	321=[4A1]BPTC-4 322=[4A1]BPR14-5
UC2	SECONDARIES	Z1 Z2	811=TA-3#16*GRA 812=TA-4#16*WHT
UC2	MDGF (M2 & M3) & NEUTRAL CT SECONDARIES	M2 M3 T3 T4	911=TA-1#16*GRA 914=TA-2#16*WHT
UC3	TRIP UNIT POWER & NEUTRAL VOLTAGE	F2+ VN F1-	A1=[4SA]SST1-14M A2=[4A1]BPTA-7 B1=[4D1]BPT1-7,[7SA]SST1-7F B2=[4D1]BPF7-A C1=[4A1]BPTF-2
MDC	PROGRAMMABLE CONTACTS	484 474 471	C2=[4A1]BPR13-10 E1=TA-7#16*GRA E2=TA-8#16*WHT E3=TA-BOUT-#22*BLK
SDET	OVERCURRENT TRIP	81 82 84	E4=TA-BOUT+ #22*RED E5=TA-BIN- #22*WHT E6=TA-BIN+ #22*GRN F1--=[4SD]SST2-2M,[5B1]BKR-F1--**GRA F2+=[4SD]SST2-1M,[5B1]BKR-F2+**RED
CE3	BREAKER CELL POSITION 'CONNECTED'	331 332 334	M1=XBA-12 M2=XBA-6*GRA53 M3=XBA-7*RED53
CE2	BREAKER CELL POSITION 'CONNECTED'	321 322 324	T3=XBA-10*GRA54 T4=XBA-11*RED54 VN=[4E2]PHIT-N7
CE1	BREAKER CELL POSITION 'CONNECTED'	311 312 314	JUMP 22 & 34 JUMP 84 & 114 JUMP A1 & C1
MX1	SHUNT TRIP	C1 C2	JUMP T1 & T2 JUMP Z3 & Z4#22 JUMP Z3 & Z5#22
XF	CLOSING COIL	A1 A2	
MCH	CHARGING MOTOR	B1 B2 B3	
OF14	AUX SWITCH	141 142 144	
OF13	AUX SWITCH	131 132 134	
OF12	AUX SWITCH	121 122 124	
OF11	AUX SWITCH	111 112 114	
OF4	AUX SWITCH	41 42 44	
OF3	AUX SWITCH	31 32 34	
OF2	AUX SWITCH	21 22 24	
OF1	AUX SWITCH	11 12 14	
CT1	BREAKER CELL POSITION 'TEST'	911 912 914	

P/N:90B0GR6, 90B0GM6B, 90B0MH10

[4B1] BPT7	
1	[4F2]GFN2-X1*RED28,[4SD]SST2-10M*GRA42
2	[4SD]SST2-11M*RED42,[7SD]SST2-11F*GRA70
3	[4F2]GFN2-X2*GRA28,[7SD]SST2-10F*RED70

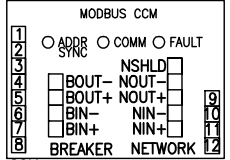
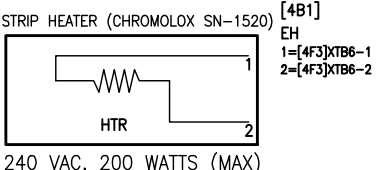
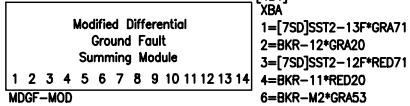

- CCM [4B1] TA
- 1=BKR-911#16*GRA
 - 2=BKR-914#16*WHT
 - 3=BKR-811#16*GRA
 - 4=BKR-812#16*WHT
 - 5=BKR-311#16*GRA
 - 6=BKR-314#16*WHT
 - 7=BKR-E1#16*GRA
 - 8=BKR-E2#16*WHT
 - 9=[4SD]SST2-8M*RED
 - 10=[5B1]TA-9*RED
 - 11=[4SD]SST2-9M*GRA
 - 12=[5B1]TA-11*GRA
 - BIN+=BKR-E6#22*GRN
 - BIN-=BKR-E5#22*WHT
 - BOUT+=BKR-E4#22*RED
 - BOUT-=BKR-E3#22*BLK
 - NIN+=[4SD]SST2-3M,[5B1]TA-NIN+##22*GRN
 - NIN-=[4SD]SST2-4M,[5B1]TA-NIN-##22*WHT
 - NOUT+=[4SD]SST2-5M,[5B1]TA-NOUT+##22*RED
 - NOUT-=[4SD]SST2-6M,[5B1]TA-NOUT-##22*BLK
 - NSHLD=[4SD]SST2-7M,[5B1]TA-NSHLD##22*SHLD

MOUNTED IN TECH STRIP

- NOTES:
- ALL #22 AWG WIRE WITH A COLOR DESIGNATION (RED, BLK, WHT, GRN) IS 2466C 4-CONDUCTOR ALPHA CABLE (OR EQUIVALENT).
 - ALL WIRE DESIGNATIONS INCLUDING A COLOR (GRA, RED) PLUS A ONE OR TWO DIGIT NUMBER INDICATE A TWISTED PAIR. FOR EXAMPLE, GRA70 AND RED70 MAKE UP A SINGLE TWISTED PAIR WIRE.
 - ROUTE ALL SHIELDED CABLE AND TWISTED PAIR WIRE IN BOTTOM WIREWAY.

SECTION [4]

JOB NAME:	JHU/APL SUBS 2 & 3 CONSOLIDATION	EQUIPMENT DESIGNATION:	SUBSTATION A
JOB LOCATION:	LAUREL MD	EQUIPMENT TYPE:	PZ4 SWITCHGEAR
DRAWN BY:	A.JEER	DRAWING TYPE:	WIRING DIAGRAM
ENGR:	S.ADONGO		
DATE:	FEBRUARY 08, 2010		
DRAWING STATUS:	RECORD	DWG#	W27452521-006-04
		PG1	OF6
		REV -	



REV	DESCRIPTION	BY	DATE								
-		-	-	-	-	-	-	-	-	-	-

CELL 4A IC

CELL 4BC TIE 5000A

CELL 4D IC

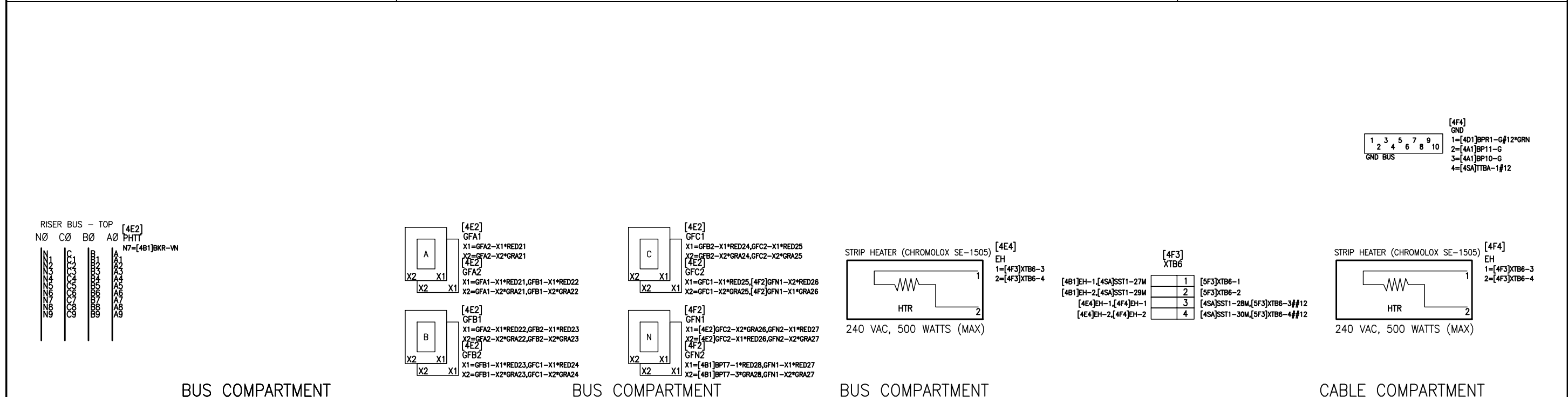

NOTES: 1. ALL #22 AWG WIRE WITH A COLOR DESIGNATION (RED, BLK, WHT, GRN) IS 2466C 4-CONDUCTOR ALPHA CABLE (OR EQUIVALENT). 2. ALL WIRE DESIGNATIONS INCLUDING A COLOR (GRA, RED) PLUS A ONE OR TWO DIGIT NUMBER INDICATE A TWISTED PAIR. FOR EXAMPLE, GRA70 AND RED70 MAKE UP A SINGLE TWISTED PAIR WIRE. 3. ROUTE ALL SHIELDED CABLE AND TWISTED PAIR WIRE IN BOTTOM WIREWAY.	JOB NAME:	JHU/APL SUBS 2 & 3 CONSOLIDATION	EQUIPMENT DESIGNATION:	SUBSTATION A	
	JOB LOCATION:	LAUREL MD	EQUIPMENT TYPE:	PZ4 SWITCHGEAR	
	DRAWN BY:	A.JEER	DRAWING TYPE:	WIRING DIAGRAM	
	ENGR:	S.ADONGO			
	DATE:	FEBRUARY 08, 2010	DWG#	W27452521-006-04	
DRAWING STATUS:	RECORD	PG	2	OF	6

SECTION [4]

REV	DESCRIPTION	BY	DATE								
---	---	---	---	---	---	---	---	---	---	---	---

CELL 4A IC

PULL APART DOOR TERMINALS

DROP 0

6 SLOT BACKPLANE P/N: TSXKRY6

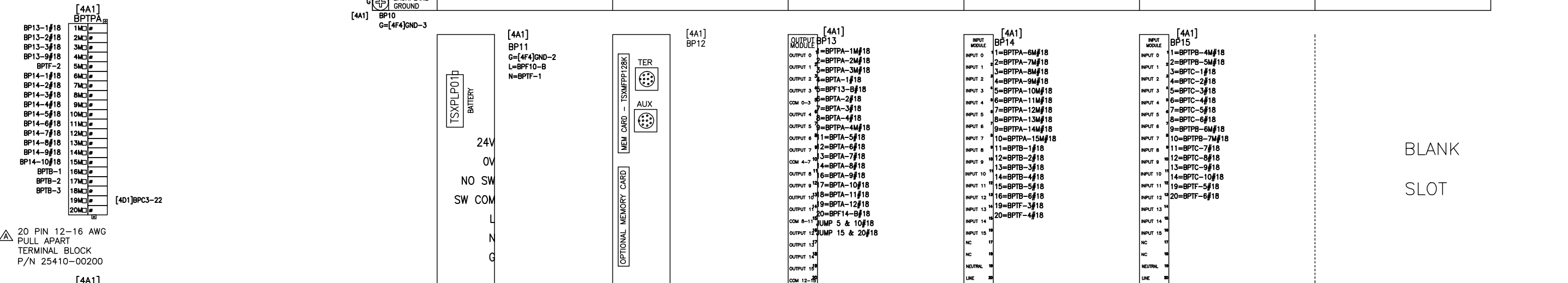

[4A1] BPTPA

BP13-1#18	1MCI
BP13-2#18	2MCI
BP13-3#18	3MCI
BP13-9#18	4MCI
BP14-1#18	5MCI
BP14-2#18	6MCI
BP14-3#18	7MCI
BP14-4#18	8MCI
BP14-5#18	9MCI
BP14-6#18	10MCI
BP14-7#18	11MCI
BP14-8#18	12MCI
BP14-9#18	13MCI
BP14-10#18	14MCI
BP14-11#18	15MCI
BP14-12#18	16MCI
BP14-13#18	17MCI
BP14-14#18	18MCI
BP14-15#18	19MCI
BP14-16#18	20MCI

20 PIN 12-16 AWG PULL APART TERMINAL BLOCK P/N 25410-00200

[4A1] BPTPB

BP15-1#18	1MCI
BP15-2#18	2MCI
BP15-9#18	3MCI
BP15-10#18	4MCI
BP15-11#18	5MCI
BP15-12#18	6MCI
BP15-13#18	7MCI
BP15-14#18	8MCI
BP15-15#18	9MCI
BP15-16#18	10MCI
BP15-17#18	11MCI
BP15-18#18	12MCI
BP15-19#18	13MCI
BP15-20#18	14MCI

15 PIN 12-16 AWG PULL APART TERMINAL BLOCK P/N 80420-625-01

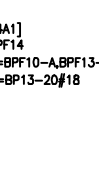
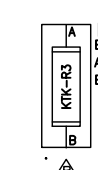
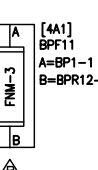
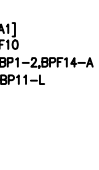
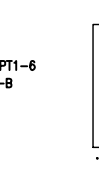
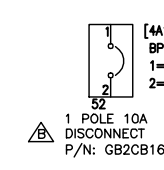

AUTO FAIL

8	7	6	5
4	3	2	1
ICECUBE RELAY			
14	11	10	9

4PDT 5A RELAY P/N: 8501NR45, 8501RS14P14V20, 8501NH45

L MAIN FAULT

8	7	6	5
4	3	2	1
ICECUBE RELAY			
14	11	10	9

4PDT 5A RELAY P/N: 8501NR45, 8501RS14P14V20, 8501NH45

R MAIN FAULT

8	7	6	5
4	3	2	1
ICECUBE RELAY			
14	11	10	9

4PDT 5A RELAY P/N: 8501NR45, 8501RS14P14V20, 8501NH45

PLC OFF-LINE

8	7	6	5
4	3	2	1
ICECUBE RELAY			
14	11	10	9

4PDT 5A RELAY P/N: 8501NR45, 8501RS14P14V20, 8501NH45

TIE FAULT

8	7	6	5
4	3	2	1
ICECUBE RELAY			
14	11	10	9

4PDT 5A RELAY P/N: 8501NR45, 8501RS14P14V20, 8501NH45

[4A1] BPTA

1	2	3	4	5	6	7	8	9	10	11	12	13	14
---	---	---	---	---	---	---	---	---	----	----	----	----	----

[4A1] BPTB

1	2	3	4	5	6
---	---	---	---	---	---

[4A1] BPTC

1	2	3	4	5	6	7	8	9	10
---	---	---	---	---	---	---	---	---	----

[4A1] BPTD

1	2	3	4	5	6	7	8	9	10
---	---	---	---	---	---	---	---	---	----

NOTES:
A PULL APART TERMINAL BLOCKS. TOP OR RIGHT PORTION (MALE) WILL BE SCREWED TO THE PAN. BOTTOM OR LEFT PORTION (FEMALE) WILL BE USED ON DOOR HARNESS SEE DOOR DETAIL.
B ALL COMPONENTS ARE PROVIDED IN PLC ASSEMBLY 80330-128/228/328-5X UNLESS OTHERWISE NOTED.

SECTION [4]

JOB NAME:	JHU/APL SUBS 2 & 3 CONSOLIDATION	EQUIPMENT DESIGNATION:	SUBSTATION A
JOB LOCATION:	LAUREL MD	EQUIPMENT TYPE:	PZ4 SWITCHGEAR
DRAWN BY:	A.JEER	DRAWING TYPE:	WIRING DIAGRAM
ENGR:	S.ADONGO		
DATE:	FEBRUARY 08, 2010		
DRAWING STATUS:	RECORD	DWG#	W27452521-006-04
		PG3	OF6
		REV	

REV	DESCRIPTION	BY	DATE						
-	-	-	-	-	-	-	-	-	-

PLC DOOR

REAR VIEW
PLC CONTROL DOOR WIRING

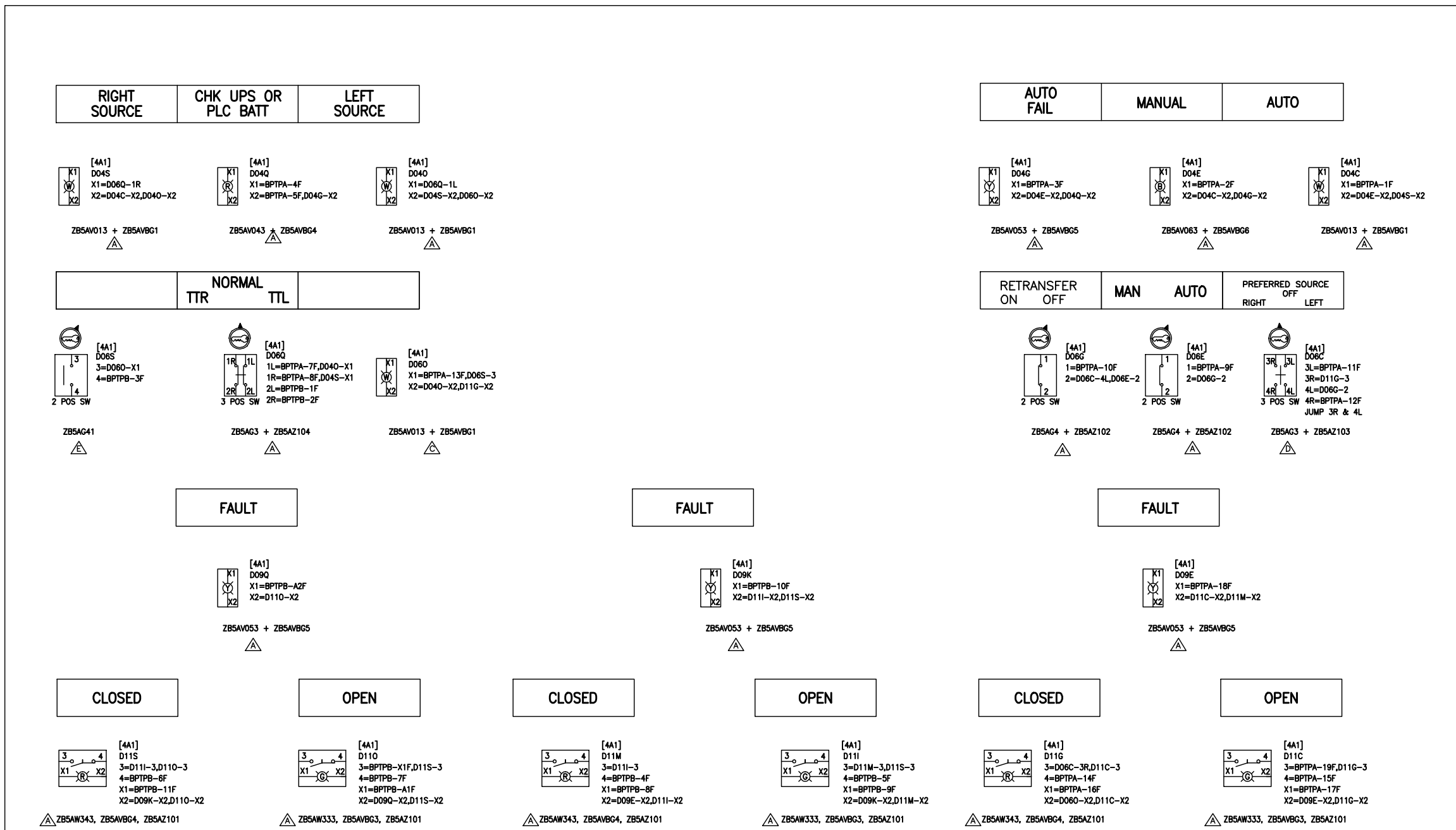

PULL APART DOOR TERMINALS

[4A1] BPTPA	
D04C-X1	1F
D04E-X1	2F
D04G-X1	3F
D04Q-X1	4F
D04Q-X2	5F
	6F
D06Q-1L	7F
D06Q-1R	8F
D06E-1	9F
D06G-1	10F
D06C-3L	11F
D06C-4R	12F
D06Q-X1	13F
D11G-4	14F
D11C-4	15F
D11G-X1	16F
D11C-X1	17F
D09E-X1	18F
D11C-3	19F
	20F

20 PIN 12-16 AWG
PULL APART
TERMINAL BLOCK
P/N 25410-00198

HINGED SIDE

[4A1] BPTPB	
D06Q-2L	1F
D06Q-2R	2F
D06S-4	3F
D11M-4	4F
D11L-4	5F
D11S-4	6F
D11O-4	7F
D11M-X1	8F
D11L-X1	9F
D09K-X1	10F
D11S-X1	11F
D11O-X1	12F
D09Q-X1	A2F
D11O-3	X1F
	X2F

15 PIN 12-16 AWG
PULL APART
TERMINAL BLOCK
P/N 80420-626-01

- △ INCLUDED IN PLC DOOR ASSEMBLY 80330-XXX-50
- △ INCLUDED IN RETRANSFER OPTION ASSEMBLY 80330-044-50
- △ INCLUDED IN SYNC PILOT LIGHT ASSEMBLY 80330-046-53
- △ INCLUDED IN PREFERRED SOURCE OPTION ASSEMBLY 80330-044-51
- △ INCLUDED IN CLOSED TRANSITION OPTION ASSEMBLY 80330-046-55
- △ INCLUDED IN EXERCISE GEN. OPTION ASSEMBLY 80330-044-52

SECTION [4]

JOB NAME:	JHU/APL SUBS 2 & 3 CONSOLIDATION	EQUIPMENT DESIGNATION:	SUBSTATION A
JOB LOCATION:	LAUREL MD	EQUIPMENT TYPE:	PZ4 SWITCHGEAR
DRAWN BY:	A.JEER	DRAWING TYPE:	WIRING DIAGRAM
ENGR:	S.ADONGO		
DATE:	FEBRUARY 08, 2010		
DRAWING STATUS:	RECORD		
DWG#	W27452521-006-04	PG	4 OF 6

REV	DESCRIPTION	BY	DATE								
-	-	-	-	-	-	-	-	-	-	-	-

CELL D INSTRUMENT COMPARTMENT

- NO COMPONENTS -

DOOR (REAR VIEW)

- NO COMPONENTS -

LEFT PAN

BACK PAN

RIGHT PAN

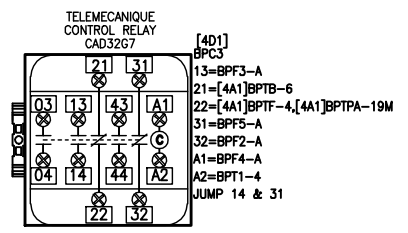
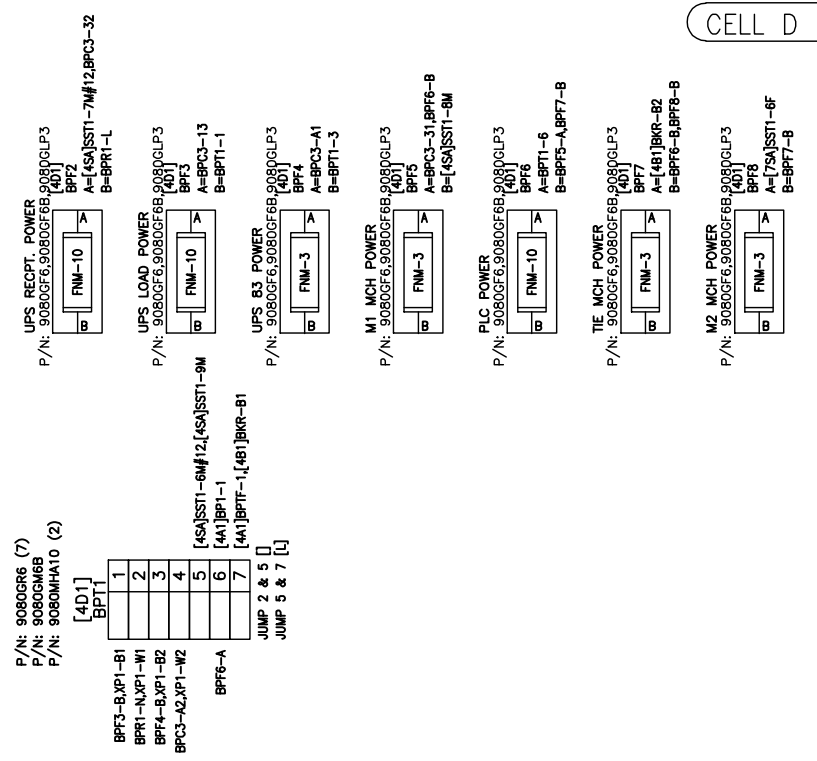

- NO COMPONENTS -

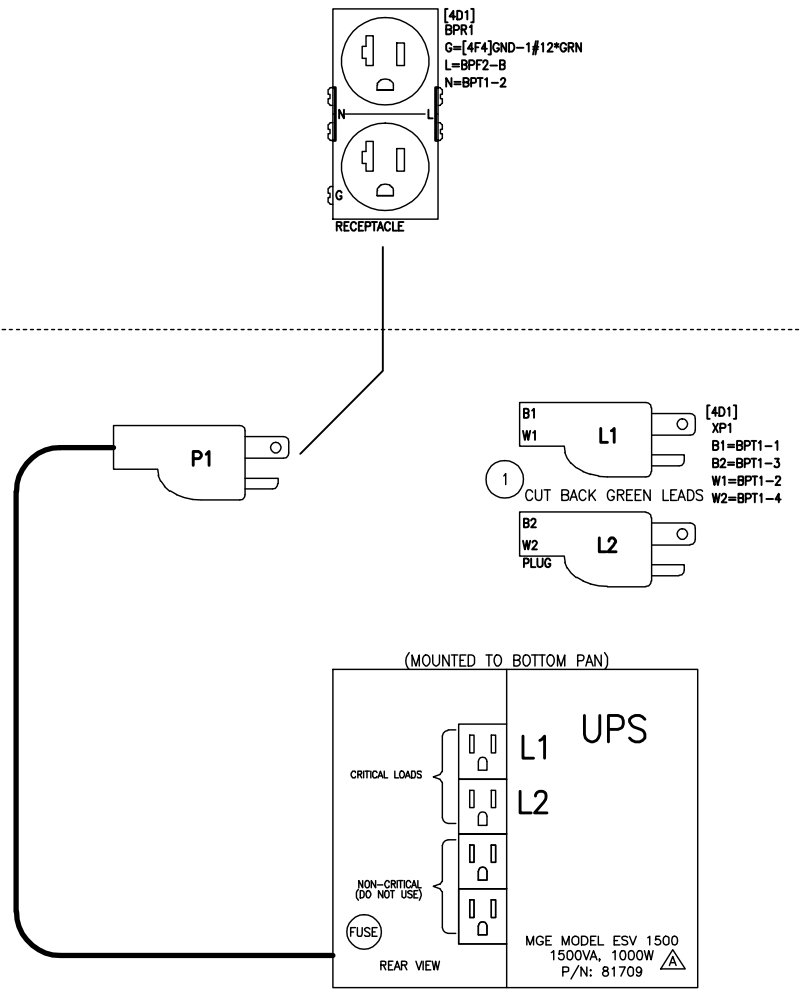

BOTTOM PAN

- NOTES:
- ALL #22 AWG WIRE WITH A COLOR DESIGNATION (RED, BLK, WHT, GRN) IS 2466C 4-CONDUCTOR ALPHA CABLE (OR EQUIVALENT).
 - ALL WIRE DESIGNATIONS INCLUDING A COLOR (GRA, RED) PLUS A ONE OR TWO DIGIT NUMBER INDICATE A TWISTED PAIR. FOR EXAMPLE, GRA70 AND RED70 MAKE UP A SINGLE TWISTED PAIR WIRE.
 - ROUTE ALL SHIELDED CABLE AND TWISTED PAIR WIRE IN BOTTOM WIREWAY.

SECTION [4]

JOB NAME:	JHU/APL SUBS 2 & 3 CONSOLIDATION	EQUIPMENT DESIGNATION:	SUBSTATION A
JOB LOCATION:	LAUREL MD	EQUIPMENT TYPE:	PZ4 SWITCHGEAR
DRAWN BY:	A.JEER	DRAWING TYPE:	WIRING DIAGRAM
ENGR:	S.ADONGO		
DATE:	FEBRUARY 08, 2010		
DRAWING STATUS:	RECORD	DWG#	W27452521-006-04
		PG5	OF6
		REV -	

REV	DESCRIPTION	BY	DATE								
A	REVERSED PT WIRING ON 7D AND XD1B ON 1A	SA	03/30/2010	-	----						

PULL-APART SHIPPING SPLIT TERMINAL BLOCKS TOP WIREWAY

[4SA]		SST1		USE PLU1-WH FOR TERMINALS 1-3	
[7SA]SST1-1F#8	1M 1F	[101]R1-GR#8			
[7SA]SST1-2F#4	2M 2F	[101]BPT1-4#4			
[7SA]SST1-3F#8	3M 3F	[101]BPT1-1#8			
[7SA]SST1-4F	4M 4F	[101]BP125-1			
[7SA]SST1-5F	5M 5F	[101]BP125-2			
[4D1]BPT1-5#12	6M 6F	[101]BPDB-N5#12			
[4D1]BPF2-A#12	7M 7F	[101]BPDB-L5#12			
[4D1]BPF5-B	8M 8F	[181]BKR-B2			
[4D1]BPT1-5	9M 9F	[181]BKR-B1			
[4A1]BPTA-5	10M 10F	[181]BKR-A2			
[4A1]BPR13-9	11M 11F	[181]BKR-C2			
[4A1]BPR13-3	12M 12F	[181]BKR-111			
[4B1]BKR-111	13M 13F	[181]BKR-114			
[4B1]BKR-A1	14M 14F	[181]BKR-A1			
[4B1]BKR-B4	15M 15F	[181]BKR-84			
[4A1]BPR11-13	16M 16F	[181]BKR-81			
[7SA]SST1-14F	17M 17F	[181]BKR-121			
[7SA]SST1-15F	18M 18F	[181]BKR-124			
[4A1]BPTB-1	19M 19F	[181]BKR-31			
[4A1]BPTB-2	20M 20F	[181]BKR-21			
[4A1]BPTB-4	21M 21F	[181]BKR-321			
[4A1]BPR11-5	22M 22F	[181]BKR-322			
[4A1]BPTPB-3M	23M 23F	[101]BP125-5			
[4A1]BPTPB-1M	24M 24F	[101]BP127-11			
[7SA]SST1-23F	25M 25F	[101]BPDB-N3			
[7SA]SST1-24F	26M 26F	[101]BPDB-L3			
[4F3]XTB6-1	27M 27F	[3F3]XTB6-1			
[4F3]XTB6-3#12	28M 28F	[3F3]XTB6-3#12			
[4F3]XTB6-2	29M 29F	[3F3]XTB6-2			
[4F3]XTB6-4#12	30M 30F	[3F3]XTB6-4#12			
[7SA]SST1-31F*RED	31M 31F	[1SA]TBA-4*RED			
[7SA]SST1-32F*RED	32M 32F	[1SA]TBA-5*RED			
TBA-3*RED	33M 33F	[3SA]TBA-3*RED			
TBA-2*WHT	34M 34F	[3SA]TBA-2*WHT			
[7SA]SST1-35F*RED	35M 35F	[1SA]TBA-6*RED			
[7SA]SST1-36F*WHT	36M 36F	[1SA]TBA-7*WHT			

PULL-APART SHIPPING SPLIT TERMINAL BLOCKS BOTTOM WIREWAY

[4SD]		SST2	
[4B1]BKR-F2+*RED	1M 1F	[3D1]BKR-F2+*RED	
[4B1]BKR-F1-*GRA	2M 2F	[3D1]BKR-F1-*GRA	
[4B1]TA-NIN+#22*GRN	3M 3F	[3D1]TA-NIN+#22*GRN	
[4B1]TA-NIN+#22*WHT	4M 4F	[3D1]TA-NIN+#22*WHT	
[4B1]TA-NOUT+#22*RED	5M 5F	[3D1]TA-NOUT+#22*RED	
[4B1]TA-NOUT+#22*BLK	6M 6F	[3D1]TA-NOUT+#22*BLK	
[4B1]TA-NSHLD#22*SHLD	7M 7F	[3D1]TA-NSHLD#22*SHLD	
[4B1]TA-9*RED	8M 8F	[3D1]TA-10*RED	
[4B1]TA-11*GRA	9M 9F	[3D1]TA-12*GRA	
[4B1]BPT7-1*GRA42	10M 10F	[1B1]XBA-1*GRA40	
[4B1]BPT7-2*RED42	11M 11F	[1B1]XBA-3*RED40	
[4B1]BKR-12*GRA43	12M 12F	[1B1]BPT7-3*GRA41	
[4B1]BKR-11*RED43	13M 13F	[1B1]BPT7-1*RED41	
	14M 14F		
	15M 15F		
	16M 16F		

- NOTES:
- ALL #22 AWG WIRE WITH A COLOR DESIGNATION (RED, BLK, WHT, GRN) IS 2466C 4-CONDUCTOR ALPHA CABLE (OR EQUIVALENT).
 - ALL WIRE DESIGNATIONS INCLUDING A COLOR (GRA, RED) PLUS A ONE OR TWO DIGIT NUMBER INDICATE A TWISTED PAIR. FOR EXAMPLE, GRA70 AND RED70 MAKE UP A SINGLE TWISTED PAIR WIRE.
 - ROUTE ALL SHIELDED CABLE AND TWISTED PAIR WIRE IN BOTTOM WIREWAY.

SECTION [4]

JOB NAME:	JHU/APL SUBS 2 & 3 CONSOLIDATION	EQUIPMENT DESIGNATION:	SUBSTATION A
JOB LOCATION:	LAUREL MD	EQUIPMENT TYPE:	PZ4 SWITCHGEAR
DRAWN BY:	A.JEER	DRAWING TYPE:	WIRING DIAGRAM
ENGR:	S.ADONGO		
DATE:	FEBRUARY 08, 2010	by Schneider Electric	
DRAWING STATUS:	RECORD	DWG#	W27452521-006-04
		PG	6 OF 6
		REV	A

REV	DESCRIPTION	BY	DATE																
---	---	---	---	---	---	---	---	---	---	---	---	---	---	---	---	---	---	---	---

CELL 5A IC

CELL 5B NW 2000A

CELL 5C NW(PS) 2000A

CELL 5D NW(PS) 2000A

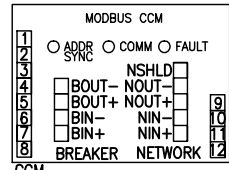
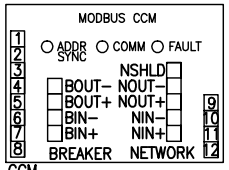
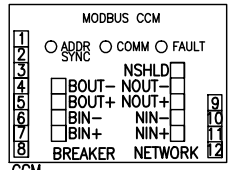
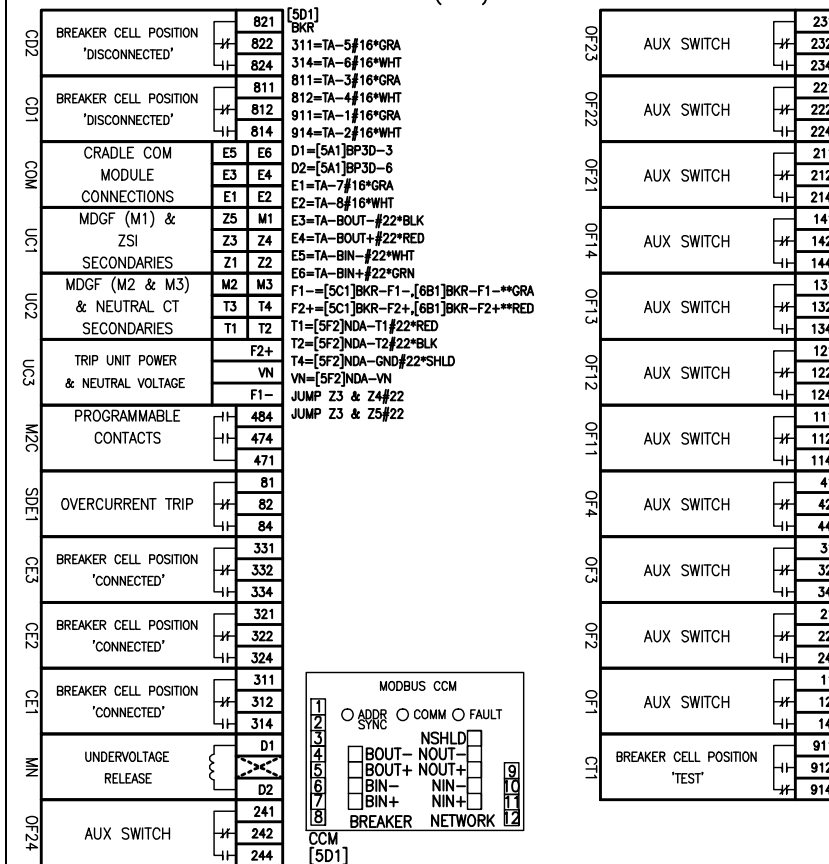
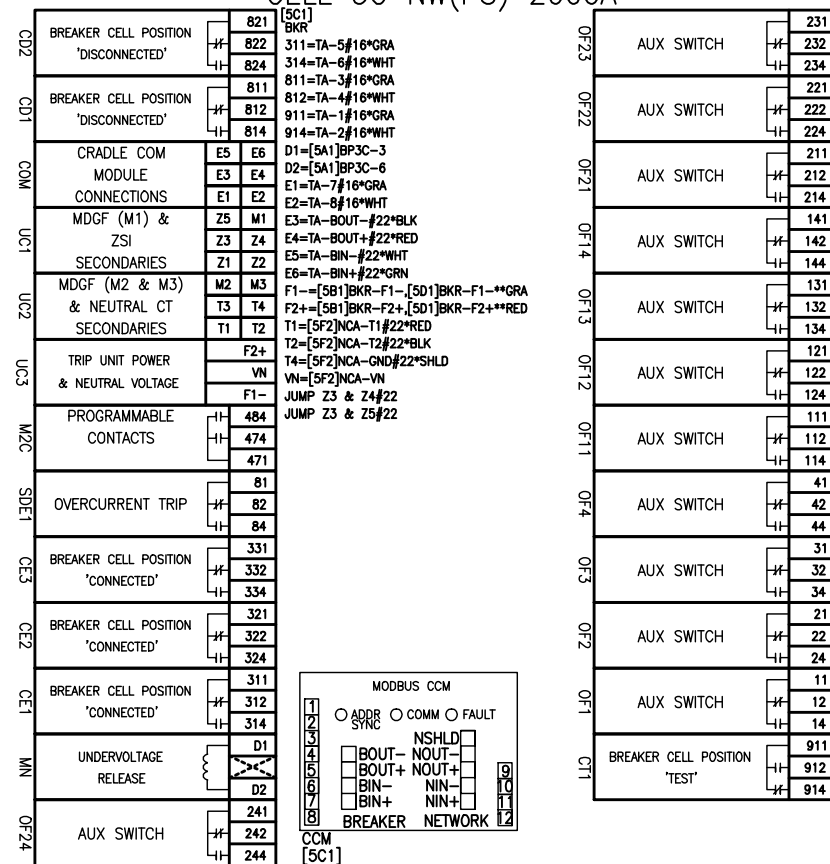
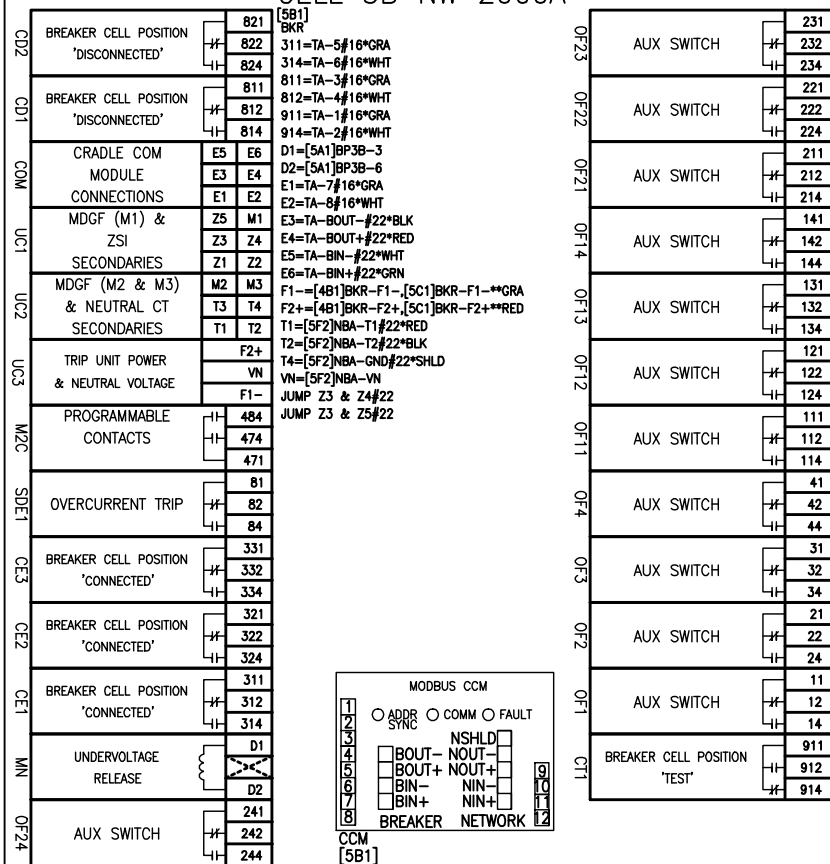

- CCM [5B1]
TA
- 1=BKR-911#16*GRA
 - 2=BKR-914#16*WHT
 - 3=BKR-811#16*GRA
 - 4=BKR-812#16*WHT
 - 5=BKR-311#16*GRA
 - 6=BKR-314#16*WHT
 - 7=BKR-E1#16*GRA
 - 8=BKR-E2#16*WHT
 - 9=[4B1]TA-10*RED
 - 10=[5C1]TA-9*RED
 - 11=[4B1]TA-12*GRA
 - 12=[5C1]TA-11*GRA
 - BIN+=BKR-E6#22*GRN
 - BIN-=BKR-E5#22*WHT
 - BOUT+=BKR-E4#22*RED
 - BOUT-=BKR-E3#22*BLK
 - NIN+=[4B1]TA-NIN+,[5C1]TA-NIN+##22*GRN
 - NIN-=[4B1]TA-NIN-,[5C1]TA-NIN-##22*WHT
 - NOUT+=[4B1]TA-NOUT+,[5C1]TA-NOUT+##22*RED
 - NOUT-=[4B1]TA-NOUT-,[5C1]TA-NOUT-##22*BLK
 - NSHLD=[4B1]TA-NSHLD,[5C1]TA-NSHLD##22*SHLD

- CCM [5C1]
TA
- 1=BKR-911#16*GRA
 - 2=BKR-914#16*WHT
 - 3=BKR-811#16*GRA
 - 4=BKR-812#16*WHT
 - 5=BKR-311#16*GRA
 - 6=BKR-314#16*WHT
 - 7=BKR-E1#16*GRA
 - 8=BKR-E2#16*WHT
 - 9=[5B1]TA-10*RED
 - 10=[5D1]TA-9*RED
 - 11=[5B1]TA-12*GRA
 - 12=[5D1]TA-11*GRA
 - BIN+=BKR-E6#22*GRN
 - BIN-=BKR-E5#22*WHT
 - BOUT+=BKR-E4#22*RED
 - BOUT-=BKR-E3#22*BLK
 - NIN+=[5B1]TA-NIN+,[5D1]TA-NIN+##22*GRN
 - NIN-=[5B1]TA-NIN-,[5D1]TA-NIN-##22*WHT
 - NOUT+=[5B1]TA-NOUT+,[5D1]TA-NOUT+##22*RED
 - NOUT-=[5B1]TA-NOUT-,[5D1]TA-NOUT-##22*BLK
 - NSHLD=[5B1]TA-NSHLD,[5D1]TA-NSHLD##22*SHLD

- CCM [5D1]
TA
- 1=BKR-911#16*GRA
 - 2=BKR-914#16*WHT
 - 3=BKR-811#16*GRA
 - 4=BKR-812#16*WHT
 - 5=BKR-311#16*GRA
 - 6=BKR-314#16*WHT
 - 7=BKR-E1#16*GRA
 - 8=BKR-E2#16*WHT
 - 9=[5C1]TA-10*RED
 - 10=[6B1]TA-9*RED
 - 11=[5C1]TA-12*GRA
 - 12=[6B1]TA-11*GRA
 - BIN+=BKR-E6#22*GRN
 - BIN-=BKR-E5#22*WHT
 - BOUT+=BKR-E4#22*RED
 - BOUT-=BKR-E3#22*BLK
 - NIN+=[5C1]TA-NIN+,[6B1]TA-NIN+##22*GRN
 - NIN-=[5C1]TA-NIN-,[6B1]TA-NIN-##22*WHT
 - NOUT+=[5C1]TA-NOUT+,[6B1]TA-NOUT+##22*RED
 - NOUT-=[5C1]TA-NOUT-,[6B1]TA-NOUT-##22*BLK
 - NSHLD=[5C1]TA-NSHLD,[6B1]TA-NSHLD##22*SHLD

MOUNTED IN TECH STRIP

MOUNTED IN TECH STRIP

MOUNTED IN TECH STRIP

- NOTES:
- ALL #22 AWG WIRE WITH A COLOR DESIGNATION (RED, BLK, WHT, GRN) IS 2466C 4-CONDUCTOR ALPHA CABLE (OR EQUIVALENT).
 - ALL WIRE DESIGNATIONS INCLUDING A COLOR (GRA, RED) PLUS A ONE OR TWO DIGIT NUMBER INDICATE A TWISTED PAIR. FOR EXAMPLE, GRA70 AND RED70 MAKE UP A SINGLE TWISTED PAIR WIRE.
 - ROUTE ALL SHIELDED CABLE AND TWISTED PAIR WIRE IN BOTTOM WIREWAY.

SECTION [5]

JOB NAME:	JHU/APL SUBS 2 & 3 CONSOLIDATION	EQUIPMENT DESIGNATION:	SUBSTATION A
JOB LOCATION:	LAUREL MD	EQUIPMENT TYPE:	PZ4 SWITCHGEAR
DRAWN BY:	A.JEER	DRAWING TYPE:	WIRING DIAGRAM
ENGR:	S.ADONGO		
DATE:	FEBRUARY 08, 2010		
DRAWING STATUS:	RECORD	DWG#	W2745251-006-05
		PG1	OF 3
		REV	---

REV	DESCRIPTION	BY	DATE							
-	-	-	-	-	-	-	-	-	-	-

CELL 5A IC

CELL 5B NW 2000A

CELL 5C NW(PS) 2000A

CELL 5D NW(PS) 2000A

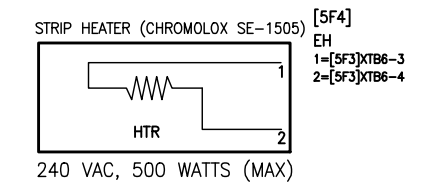
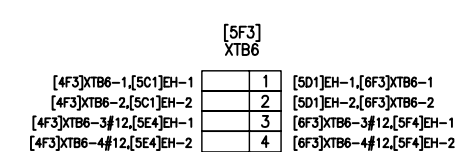
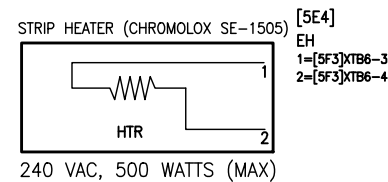
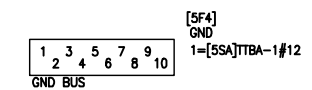
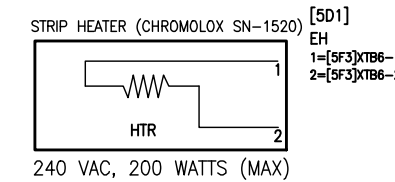
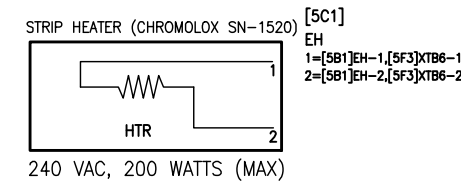
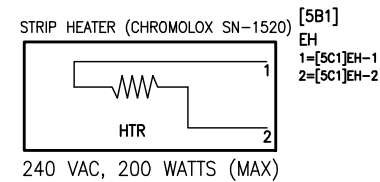
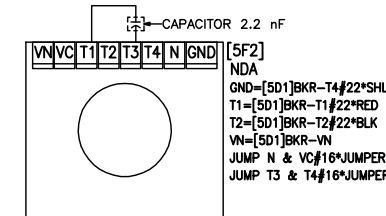
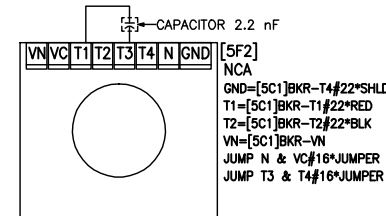
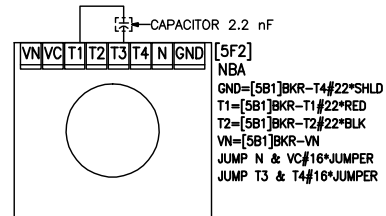

BUS COMPARTMENT

BUS COMPARTMENT

CABLE COMPARTMENT

- NOTES:
- ALL #22 AWG WIRE WITH A COLOR DESIGNATION (RED, BLK, WHT, GRN) IS 2466C 4-CONDUCTOR ALPHA CABLE (OR EQUIVALENT).
 - ALL WIRE DESIGNATIONS INCLUDING A COLOR (GRA, RED) PLUS A ONE OR TWO DIGIT NUMBER INDICATE A TWISTED PAIR. FOR EXAMPLE, GRA70 AND RED70 MAKE UP A SINGLE TWISTED PAIR WIRE.
 - ROUTE ALL SHIELDED CABLE AND TWISTED PAIR WIRE IN BOTTOM WIREWAY.

SECTION [5]

JOB NAME:	JHU/APL SUBS 2 & 3 CONSOLIDATION	EQUIPMENT DESIGNATION:	SUBSTATION A
JOB LOCATION:	LAUREL MD	EQUIPMENT TYPE:	PZ4 SWITCHGEAR
DRAWN BY:	A.JEER	DRAWING TYPE:	WIRING DIAGRAM
ENGR:	S.ADONGO		
DATE:	FEBRUARY 08, 2010		
DRAWING STATUS:	RECORD	DWG#	W27452521-006-05



REV	DESCRIPTION	BY	DATE										
-	-	-	-	-	-	-	-	-	-	-	-	-	-

CELL A INSTRUMENT COMPARTMENT

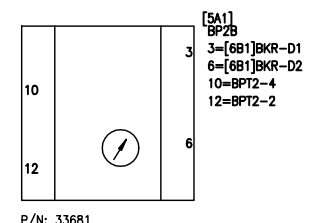

P/N: 33681

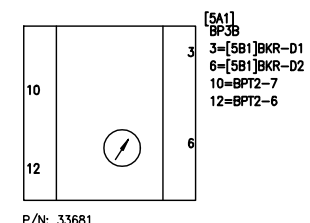

P/N: 33681

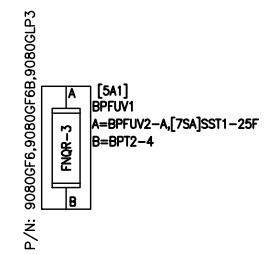

P/N: 9080GFE,9080GFB,9080GLP3

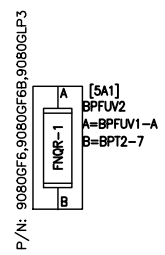

P/N: 9080GFE,9080GFB,9080GLP3

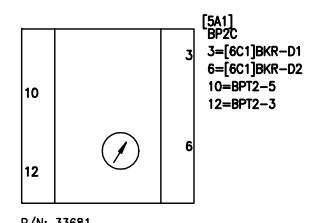

P/N: 33681

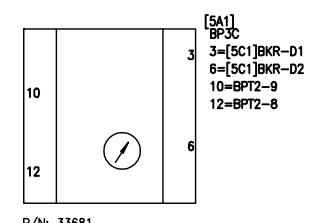

P/N: 33681

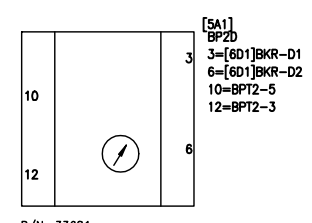
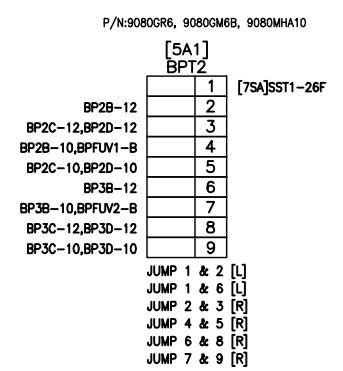

P/N: 33681

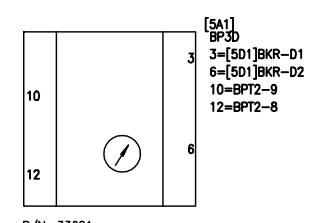

P/N: 33681

LEFT PAN

BACK PAN

RIGHT PAN

BOTTOM PAN

- NOTES:
- ALL #22 AWG WIRE WITH A COLOR DESIGNATION (RED, BLK, WHT, GRN) IS 2466C 4-CONDUCTOR ALPHA CABLE (OR EQUIVALENT).
 - ALL WIRE DESIGNATIONS INCLUDING A COLOR (GRA, RED) PLUS A ONE OR TWO DIGIT NUMBER INDICATE A TWISTED PAIR. FOR EXAMPLE, GRA70 AND RED70 MAKE UP A SINGLE TWISTED PAIR WIRE.
 - ROUTE ALL SHIELDED CABLE AND TWISTED PAIR WIRE IN BOTTOM WIREWAY.

SECTION [5]

JOB NAME:	JHU/APL SUBS 2 & 3 CONSOLIDATION	EQUIPMENT DESIGNATION:	SUBSTATION A
JOB LOCATION:	LAUREL MD	EQUIPMENT TYPE:	PZ4 SWITCHGEAR
DRAWN BY:	A.JEER	DRAWING TYPE:	WIRING DIAGRAM
ENGR:	S.ADONGO		
DATE:	FEBRUARY 08, 2010		
DRAWING STATUS:	RECORD	DWG#	W2745251-006-05
		PG	3 OF 3
		REV	-

REV	DESCRIPTION	BY	DATE																	
-	-	-	-	-	-	-	-	-	-	-	-	-	-	-	-	-	-	-	-	-

CELL 6A BLK

CELL 6B NW 2000A

CELL 6C NW 2000A

CELL 6D NW(PS) 2000A

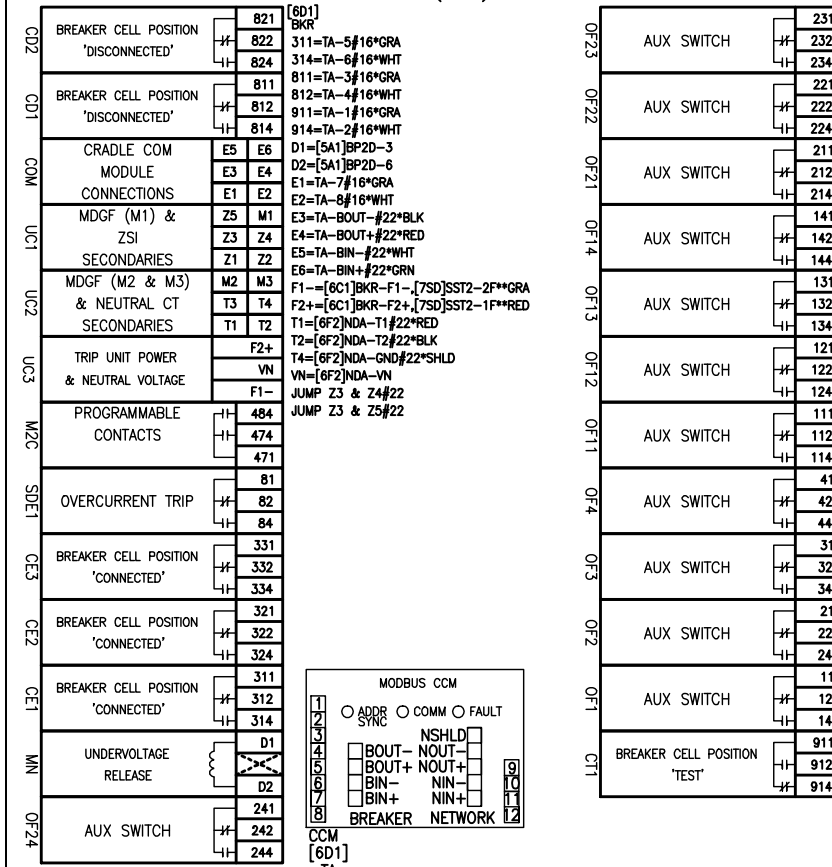
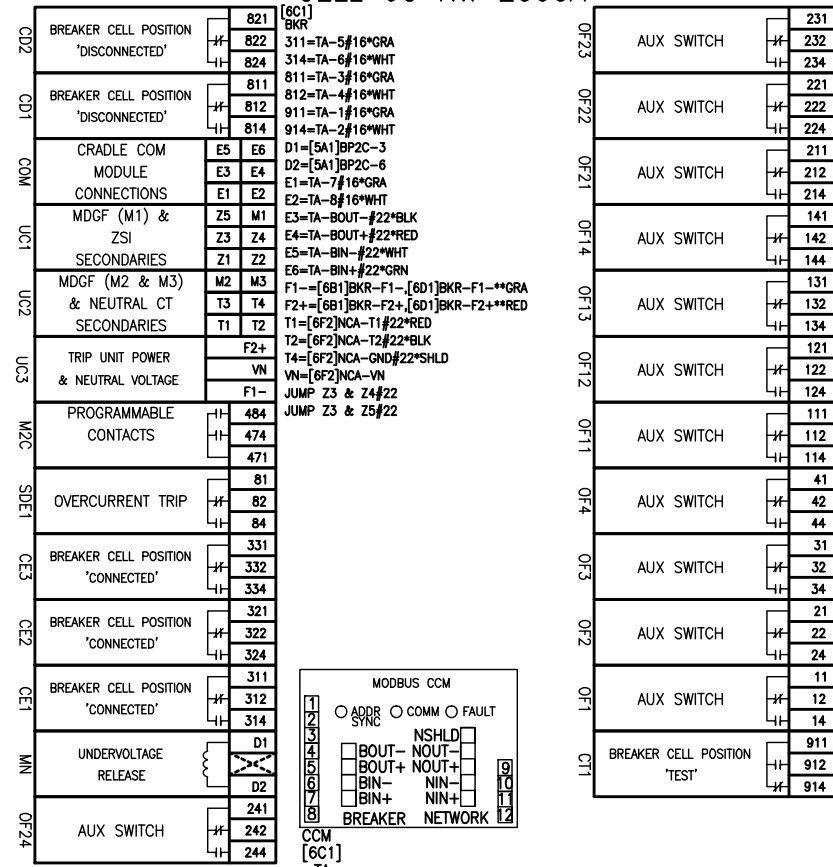
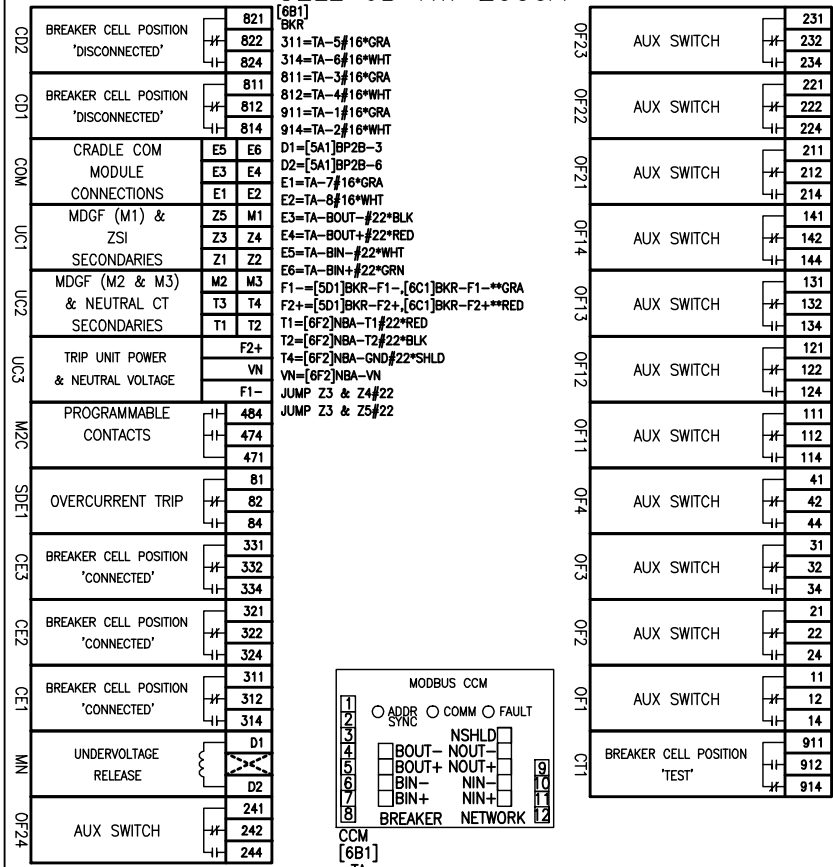

- MODBUS CCM
- ADDR COMM FAULT
 SYNC
- NSHLD
 BOUT- NOUT-
 BOUT+ NOUT+
 BIN- NIN-
 BIN+ NIN+
- BREAKER NETWORK
- CCM [6B1]
- TA
- 1=BKR-911#16*GRA
 - 2=BKR-914#16*WHT
 - 3=BKR-811#16*GRA
 - 4=BKR-812#16*WHT
 - 5=BKR-311#16*GRA
 - 6=BKR-314#16*WHT
 - 7=BKR-E1#16*GRA
 - 8=BKR-E2#16*WHT
 - 9=[5D1]TA-10*RED
 - 10=[6C1]TA-9*RED
 - 11=[5D1]TA-12*GRA
 - 12=[6C1]TA-11*GRA
 - BIN+=BKR-E6#22*GRN
 - BIN-=BKR-E5#22*WHT
 - BOUT+=BKR-E4#22*RED
 - BOUT-=BKR-E3#22*BLK
 - NIN+=[5D1]TA-NIN+,[6C1]TA-NIN+##22*GRN
 - NIN-=[5D1]TA-NIN-,[6C1]TA-NIN-##22*WHT
 - NOUT+=[5D1]TA-NOUT+,[6C1]TA-NOUT+##22*RED
 - NOUT-=[5D1]TA-NOUT-,[6C1]TA-NOUT-##22*BLK
 - NSHLD=[5D1]TA-NSHLD,[6C1]TA-NSHLD##22*SHLD

- MODBUS CCM
- ADDR COMM FAULT
 SYNC
- NSHLD
 BOUT- NOUT-
 BOUT+ NOUT+
 BIN- NIN-
 BIN+ NIN+
- BREAKER NETWORK
- CCM [6C1]
- TA
- 1=BKR-911#16*GRA
 - 2=BKR-914#16*WHT
 - 3=BKR-811#16*GRA
 - 4=BKR-812#16*WHT
 - 5=BKR-311#16*GRA
 - 6=BKR-314#16*WHT
 - 7=BKR-E1#16*GRA
 - 8=BKR-E2#16*WHT
 - 9=[6B1]TA-10*RED
 - 10=[6D1]TA-9*RED
 - 11=[6B1]TA-12*GRA
 - 12=[6D1]TA-11*GRA
 - BIN+=BKR-E6#22*GRN
 - BIN-=BKR-E5#22*WHT
 - BOUT+=BKR-E4#22*RED
 - BOUT-=BKR-E3#22*BLK
 - NIN+=[6B1]TA-NIN+,[6D1]TA-NIN+##22*GRN
 - NIN-=[6B1]TA-NIN-,[6D1]TA-NIN-##22*WHT
 - NOUT+=[6B1]TA-NOUT+,[6D1]TA-NOUT+##22*RED
 - NOUT-=[6B1]TA-NOUT-,[6D1]TA-NOUT-##22*BLK
 - NSHLD=[6B1]TA-NSHLD,[6D1]TA-NSHLD##22*SHLD

- MODBUS CCM
- ADDR COMM FAULT
 SYNC
- NSHLD
 BOUT- NOUT-
 BOUT+ NOUT+
 BIN- NIN-
 BIN+ NIN+
- BREAKER NETWORK
- CCM [6D1]
- TA
- 1=BKR-911#16*GRA
 - 2=BKR-914#16*WHT
 - 3=BKR-811#16*GRA
 - 4=BKR-812#16*WHT
 - 5=BKR-311#16*GRA
 - 6=BKR-314#16*WHT
 - 7=BKR-E1#16*GRA
 - 8=BKR-E2#16*WHT
 - 9=[6C1]TA-10*RED
 - 10=[7SD]SST2-7F*RED
 - 11=[6C1]TA-12*GRA
 - 12=[7SD]SST2-8F*GRA
 - BIN+=BKR-E6#22*GRN
 - BIN-=BKR-E5#22*WHT
 - BOUT+=BKR-E4#22*RED
 - BOUT-=BKR-E3#22*BLK
 - NIN+=[6C1]TA-NIN+,[7SD]SST2-3F##22*GRN
 - NIN-=[6C1]TA-NIN-,[7SD]SST2-4F##22*WHT
 - NOUT+=[6C1]TA-NOUT+,[7SD]SST2-5F##22*RED
 - NOUT-=[6C1]TA-NOUT-,[7SD]SST2-6F##22*BLK
 - NSHLD=[6C1]TA-NSHLD,[7SD]SST2-9F##22*SHLD

MOUNTED IN TECH STRIP

MOUNTED IN TECH STRIP

MOUNTED IN TECH STRIP

- NOTES:
- ALL #22 AWG WIRE WITH A COLOR DESIGNATION (RED, BLK, WHT, GRN) IS 2466C 4-CONDUCTOR ALPHA CABLE (OR EQUIVALENT).
 - ALL WIRE DESIGNATIONS INCLUDING A COLOR (GRA, RED) PLUS A ONE OR TWO DIGIT NUMBER INDICATE A TWISTED PAIR. FOR EXAMPLE, GRA70 AND RED70 MAKE UP A SINGLE TWISTED PAIR WIRE.
 - ROUTE ALL SHIELDED CABLE AND TWISTED PAIR WIRE IN BOTTOM WIREWAY.

SECTION [6]

JOB NAME:	JHU/APL SUBS 2 & 3 CONSOLIDATION	EQUIPMENT DESIGNATION:	SUBSTATION A
JOB LOCATION:	LAUREL MD	EQUIPMENT TYPE:	PZ4 SWITCHGEAR
DRAWN BY:	A.JEER	DRAWING TYPE:	WIRING DIAGRAM
ENGR:	S.ADONGO		
DATE:	FEBRUARY 08, 2010		
DRAWING STATUS:	RECORD	DWG#	W2745251-006-06
		PG1	OF 2
		REV	-

REV	DESCRIPTION	BY	DATE								
-	-	-	-	-	-	-	-	-	-	-	-

CELL 6A BLK

CELL 6B NW 2000A

CELL 6C NW 1600A

CELL 6D NW(PS) 2000A

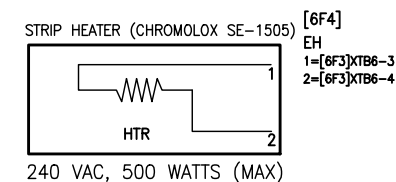
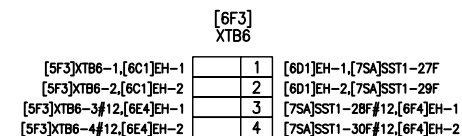
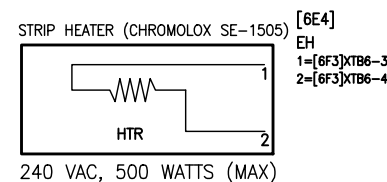
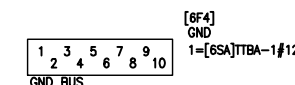
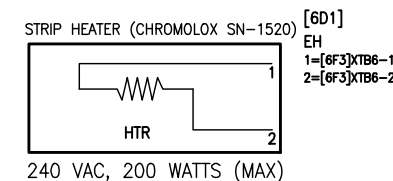
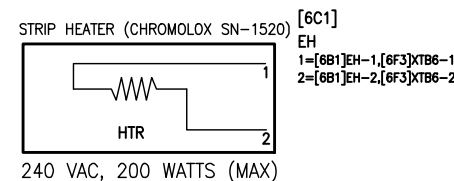
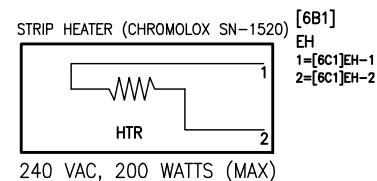
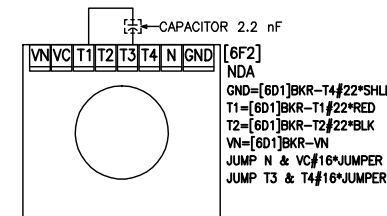
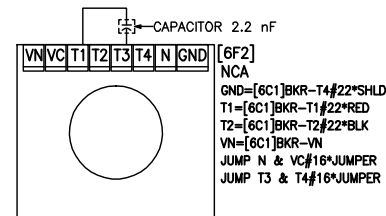
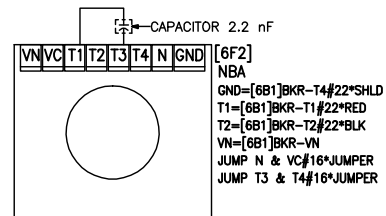

BUS COMPARTMENT

BUS COMPARTMENT

CABLE COMPARTMENT

- NOTES:
- ALL #22 AWG WIRE WITH A COLOR DESIGNATION (RED, BLK, WHT, GRN) IS 2466C 4-CONDUCTOR ALPHA CABLE (OR EQUIVALENT).
 - ALL WIRE DESIGNATIONS INCLUDING A COLOR (GRA, RED) PLUS A ONE OR TWO DIGIT NUMBER INDICATE A TWISTED PAIR. FOR EXAMPLE, GRA70 AND RED70 MAKE UP A SINGLE TWISTED PAIR WIRE.
 - ROUTE ALL SHIELDED CABLE AND TWISTED PAIR WIRE IN BOTTOM WIREWAY.

SECTION [6]

JOB NAME:	JHU/APL SUBS 2 & 3 CONSOLIDATION	EQUIPMENT DESIGNATION:	SUBSTATION A
JOB LOCATION:	LAUREL MD	EQUIPMENT TYPE:	PZ4 SWITCHGEAR
DRAWN BY:	A.JEER	DRAWING TYPE:	WIRING DIAGRAM
ENGR:	S.ADONGO		
DATE:	FEBRUARY 08, 2010		
DRAWING STATUS:	RECORD	DWG#	W27452521-006-06

PG2 OF2 REV -

REV	DESCRIPTION	BY	DATE											
-	-	-	-	-	-	-	-	-	-	-	-	-	-	-

CELL 7A IC

CELL 7BC MN 5000A

CD2	BREAKER CELL POSITION 'DISCONNECTED'	821 822 824	[7B1] BKR 11=BPT7-3*RED11,XBA-4*GRA30 12=BPT7-2*GRA11,XBA-2*RED30 21=[7SA]SST1-20M
CD1	BREAKER CELL POSITION 'DISCONNECTED'	811 812 814	31=[7SA]SST1-19M 81=[7SA]SST1-16M 84=[7SA]SST1-15M
COM	CRADLE COM MODULE CONNECTIONS	E5 E6 E3 E4 E1 E2	111=[7SA]SST1-11M 114=[7SA]SST1-12M 121=[7SA]SST1-13M 124=[7SA]SST1-14M
UC1	MDGF (M1) & ZSI	Z5 M1 Z3 Z4	311=TA-5#16*GRA 314=TA-6#16*WHT
UC2	SECONDARIES	Z1 Z2	321=[7SA]SST1-21M 322=[7SA]SST1-22M
UC3	MDGF (M2 & M3) & NEUTRAL CT SECONDARIES	M2 M3 T3 T4 T1 T2	811=TA-3#16*GRA 812=TA-4#16*WHT 911=TA-1#16*GRA 914=TA-2#16*WHT
UC3	TRIP UNIT POWER & NEUTRAL VOLTAGE	F2+ VN F1-	A2=[7SA]SST1-8M B1=[7SA]SST1-7M B2=[7SA]SST1-6M
MDC	PROGRAMMABLE CONTACTS	484 474 471	C1=[7SA]SST1-10M C2=[7SA]SST1-9M E1=TA-7#16*GRA E2=TA-8#16*WHT
SSET	OVERCURRENT TRIP	81 82 84	E3=TA-BOUT-#22*BLK E4=TA-BOUT-#22*RED E5=TA-BIN-#22*WHT E6=TA-BIN-#22*GRN
CE3	BREAKER CELL POSITION 'CONNECTED'	331 332 334	F1=[7SD]SST2-2M*GRA F2=[7SD]SST2-1M*RED M1=XBA-12
CE2	BREAKER CELL POSITION 'CONNECTED'	321 322 324	M2=XBA-6*GRA55 M3=XBA-7*RED55 T3=XBA-10*GRA56 T4=XBA-11*RED56
CE1	BREAKER CELL POSITION 'CONNECTED'	311 312 314	VN=[7E2]PHIT-N7 JUMP 22 & 34 JUMP 22 & 322 JUMP A1 & C1
MX1	SHUNT TRIP	C1 C2	JUMP T1 & T2 JUMP Z3 & Z4#22 JUMP Z3 & Z5#22
XF	CLOSING COIL	A1 A2	
MCH	CHARGING MOTOR	B1 B2 B3	
OF4	AUX SWITCH	141 142 144	1=BKR-911#16*GRA 2=BKR-914#16*WHT 3=BKR-811#16*GRA 4=BKR-812#16*WHT
OF3	AUX SWITCH	131 132 134	5=BKR-311#16*GRA 6=BKR-314#16*WHT 7=BKR-E1#16*GRA 8=BKR-E2#16*WHT
OF12	AUX SWITCH	121 122 124	9=[7SD]SST2-7M*RED 11=[7SD]SST2-8M*GRA BIN+=BKR-E6#22*GRN BIN-=BKR-E5#22*WHT BOUT+=BKR-E4#22*RED BOUT-=BKR-E3#22*BLK
OF11	AUX SWITCH	111 112 114	NIN+=[7A1]BPTZ4-1,[7SD]SST2-3M#22*GRN NIN-=[7A1]BPTZ4-3,[7SD]SST2-4M#22*WHT NOUT+=[7A1]BPTZ4-5,[7SD]SST2-5M#22*RED NOUT-=[7A1]BPTZ4-7,[7SD]SST2-6M#22*BLK NSHLD=[7A1]BPTZ4-9,[7SD]SST2-9M#22*SHLD
OF4	AUX SWITCH	41 42 44	
OF3	AUX SWITCH	31 32 34	
OF2	AUX SWITCH	21 22 24	
OF1	AUX SWITCH	11 12 14	
CT1	BREAKER CELL POSITION 'TEST'	911 912 914	

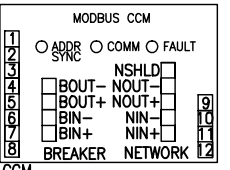

- CCM [7B1] TA
- 1=BKR-911#16*GRA
 - 2=BKR-914#16*WHT
 - 3=BKR-811#16*GRA
 - 4=BKR-812#16*WHT
 - 5=BKR-311#16*GRA
 - 6=BKR-314#16*WHT
 - 7=BKR-E1#16*GRA
 - 8=BKR-E2#16*WHT
 - 9=[7SD]SST2-7M*RED
 - 11=[7SD]SST2-8M*GRA
 - BIN+=BKR-E6#22*GRN
 - BIN-=BKR-E5#22*WHT
 - BOUT+=BKR-E4#22*RED
 - BOUT-=BKR-E3#22*BLK
 - NIN+=[7A1]BPTZ4-1,[7SD]SST2-3M#22*GRN
 - NIN-=[7A1]BPTZ4-3,[7SD]SST2-4M#22*WHT
 - NOUT+=[7A1]BPTZ4-5,[7SD]SST2-5M#22*RED
 - NOUT-=[7A1]BPTZ4-7,[7SD]SST2-6M#22*BLK
 - NSHLD=[7A1]BPTZ4-9,[7SD]SST2-9M#22*SHLD

P/N:9080GR6, 9080M6B, 9080MH10

[7B1] BPT7	1	[7F2]GFN2-X1*RED38,[7SD]SST2-12M*RED73
BKR-12*GRA11	2	[7SD]SST2-13M*GRA73
BKR-11*RED11	3	[7F2]GFN2-X2*GRA38

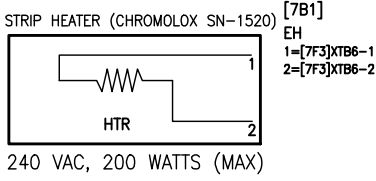
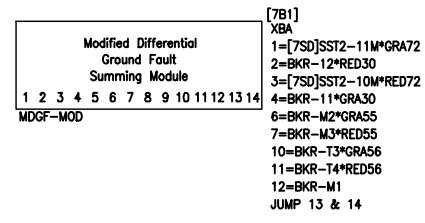

MOUNTED IN CRADLE

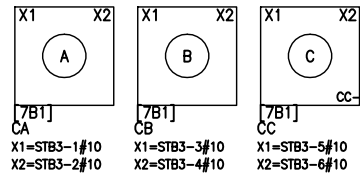

- P/N: 27110-00000 [7B1] STB3
- CA-X1#10 1 1A [7A1]BP3-8
 - CA-X2#10 2 2A
 - CB-X1#10 3 3A [7A1]BP3-6
 - CB-X2#10 4 4A
 - CC-X1#10 5 5A [7A1]BP3-4
 - CC-X2#10,[7F4]GND-3#12*GRN 6 6A [7A1]BP3-3
- JUMP 2A & 4A
JUMP 4A & 6A

MOUNTED IN TECH STRIP

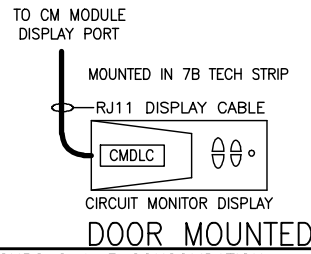

NOTES:
1. ALL #22 AWG WIRE WITH A COLOR DESIGNATION (RED, BLK, WHT, GRN) IS 2466C 4-CONDUCTOR ALPHA CABLE (OR EQUIVALENT).
2. ALL WIRE DESIGNATIONS INCLUDING A COLOR (GRA, RED) PLUS A ONE OR TWO DIGIT NUMBER INDICATE A TWISTED PAIR. FOR EXAMPLE, GRA70 AND RED70 MAKE UP A SINGLE TWISTED PAIR WIRE.
3. ROUTE ALL SHIELDED CABLE AND TWISTED PAIR WIRE IN BOTTOM WIREWAY.

SECTION [7]

JOB NAME:	JHU/APL SUBS 2 & 3 CONSOLIDATION	EQUIPMENT DESIGNATION:	STATION A
JOB LOCATION:	LAUREL MD	EQUIPMENT TYPE:	PZ4 SWITCHGEAR
DRAWN BY:	A.JEER	DRAWING TYPE:	WIRING DIAGRAM
ENGR:	S.ADONGO		
DATE:	FEBRUARY 08, 2010		
DRAWING STATUS:	RECORD	DWG#	W2745251-006-07
		PG1	OF4
		REV	-

REV	DESCRIPTION	BY	DATE	B	REVERSED X2/H2 ON X25 PT	SA	04/06/2010	-	----	--	--/--/--
A	REVERSED PT WIRING ON 7D AND XD1B ON 1A	SA	03/30/2010	C	UPDATED PT TERMINAL WIRING	SA	04/07/2010	-	----	--	--/--/--

CELL 7A IC

CELL 7BC MN 5000A

CELL 7D IC

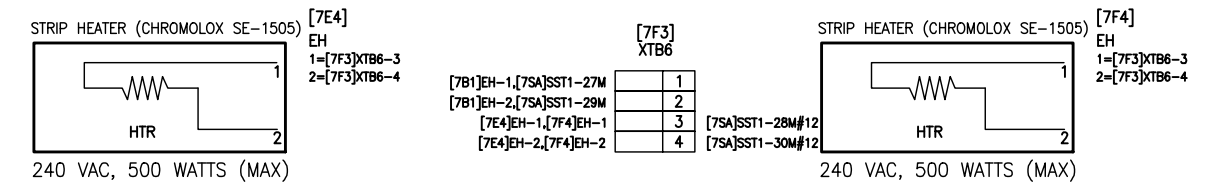
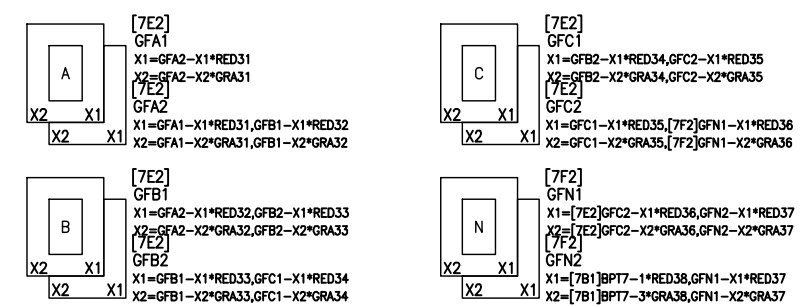
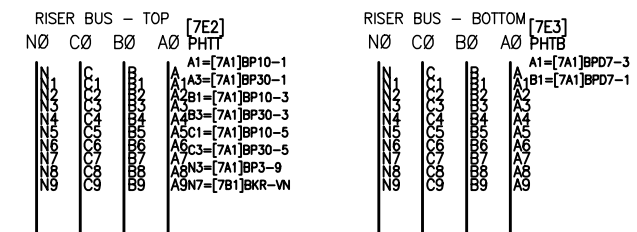
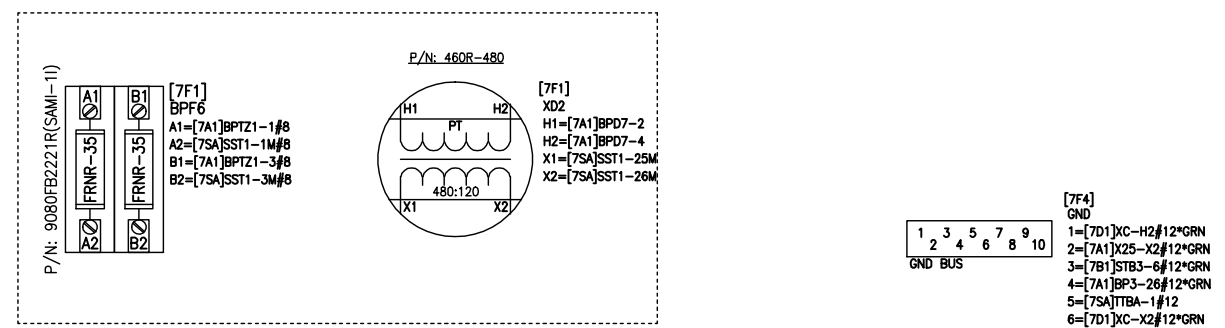
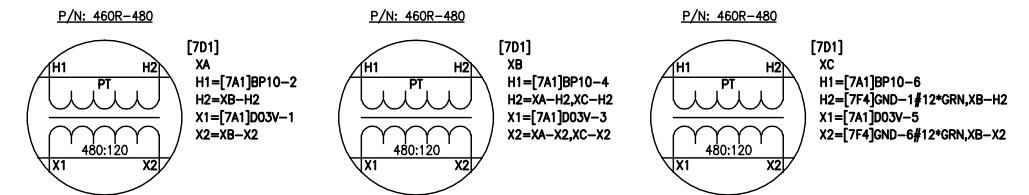

BUS COMPARTMENT

BUS COMPARTMENT

BUS COMPARTMENT

CABLE COMPARTMENT

NOTES:
1. ALL #22 AWG WIRE WITH A COLOR DESIGNATION (RED, BLK, WHT, GRN) IS 2466C 4-CONDUCTOR ALPHA CABLE (OR EQUIVALENT).
2. ALL WIRE DESIGNATIONS INCLUDING A COLOR (GRA, RED) PLUS A ONE OR TWO DIGIT NUMBER INDICATE A TWISTED PAIR. FOR EXAMPLE, GRA70 AND RED70 MAKE UP A SINGLE TWISTED PAIR WIRE.
3. ROUTE ALL SHIELDED CABLE AND TWISTED PAIR WIRE IN BOTTOM WIREWAY.

SECTION [7]

JOB NAME:	JHU/APL SUBS 2 & 3 CONSOLIDATION	EQUIPMENT DESIGNATION:	SUBSTATION A
JOB LOCATION:	LAUREL MD	EQUIPMENT TYPE:	PZ4 SWITCHGEAR
DRAWN BY:	A.JEER	DRAWING TYPE:	WIRING DIAGRAM
ENGR:	S.ADONGO		
DATE:	FEBRUARY 08, 2010	by Schneider Electric	
DRAWING STATUS:	RECORD	DWG#	W2745251-006-07
		PG2	OF 4
		REV C	

REV	DESCRIPTION	BY	DATE	B	REVERSED X2/H2 ON X25 PT	SA	04/06/2010	-	----	--	--/--/--
A	REVERSED PT WIRING ON 7D AND XD1B ON 1A	SA	03/30/2010	C	UPDATED PT TERMINAL WIRING	SA	04/07/2010	-	----	--	--/--/--

CELL A INSTRUMENT COMPARTMENT

CELL 7A IC

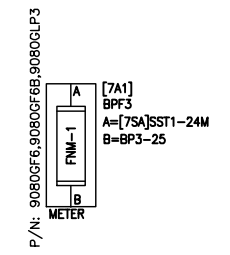
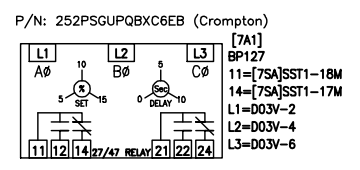
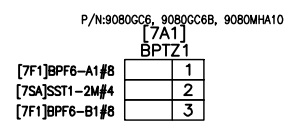
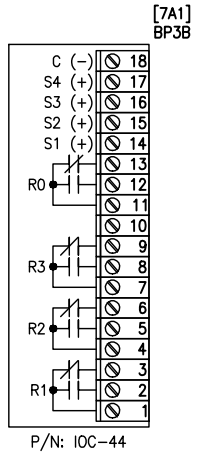
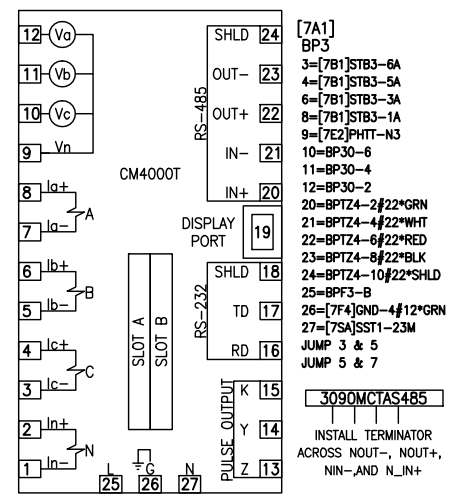
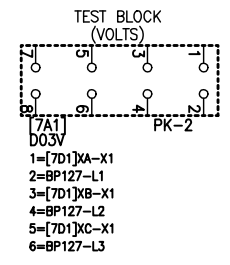

- NO COMPONENTS -

- NO COMPONENTS -

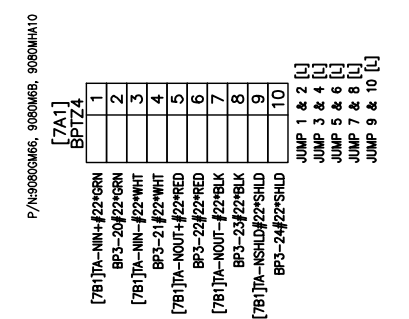
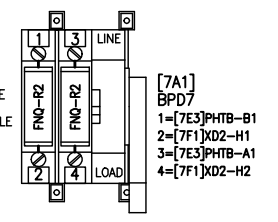
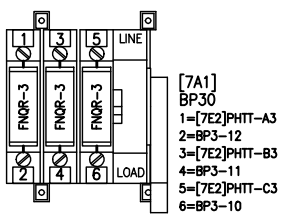
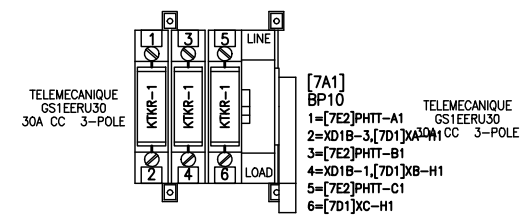

BACK PAN

RIGHT PAN

LEFT PAN

BOTTOM PAN

- NOTES:
- ALL #22 AWG WIRE WITH A COLOR DESIGNATION (RED, BLK, WHT, GRN) IS 2466C 4-CONDUCTOR ALPHA CABLE (OR EQUIVALENT).
 - ALL WIRE DESIGNATIONS INCLUDING A COLOR (GRA, RED) PLUS A ONE OR TWO DIGIT NUMBER INDICATE A TWISTED PAIR. FOR EXAMPLE, GRA70 AND RED70 MAKE UP A SINGLE TWISTED PAIR WIRE.
 - ROUTE ALL SHIELDED CABLE AND TWISTED PAIR WIRE IN BOTTOM WIREWAY.

SECTION [7]

JOB NAME:	JHU/APL SUBS 2 & 3 CONSOLIDATION	EQUIPMENT DESIGNATION:	SUBSTATION A
JOB LOCATION:	LAUREL MD	EQUIPMENT TYPE:	PZ4 SWITCHGEAR
DRAWN BY:	A.JEER	DRAWING TYPE:	WIRING DIAGRAM
ENGR:	S.ADONGO		
DATE:	FEBRUARY 08, 2010		
DRAWING STATUS:	RECORD	DWG#	W27452521-006-07
		PG	3 OF 4
		REV	C

REV	DESCRIPTION	BY	DATE	B	UPDATED PT	TERMINAL WIRING	SA	04/07/2010	-	----	--	--/--/--
A	REVERSED PT WIRING ON 7D AND XD1B ON 1A	SA	03/30/2010	-	----		--	--/--/--	-	----	--	--/--/--

PULL-APART SHIPPING SPLIT TERMINAL BLOCKS
TOP WIREWAY

[7SA]		
SST1		
[7F1]BPF6-A2#8	1M 1F	[4SA]SST1-1M#8
[7A1]BPTZ1-2#4	2M 2F	[4SA]SST1-2M#4
[7F1]BPF6-B2#8	3M 3F	[4SA]SST1-3M#8
[7A1]XF25-A	4M 4F	[4SA]SST1-4M
[7A1]X25-X2	5M 5F	[4SA]SST1-5M
[7B1]BKR-B2	6M 6F	[4D1]BPF8-A
[7B1]BKR-B1	7M 7F	[4B1]BKR-B1
[7B1]BKR-A2	8M 8F	[4A1]BPTA-9
[7B1]BKR-C2	9M 9F	[4A1]BPR13-11
[7B1]BKR-C1	10M 10F	[4A1]BPTF-2
[7B1]BKR-111	11M 11F	[4A1]BPR14-6
[7B1]BKR-114	12M 12F	[4A1]BPR13-1
[7B1]BKR-121	13M 13F	[4A1]BPR12-6
[7B1]BKR-124	14M 14F	[4SA]SST1-17M
[7B1]BKR-84	15M 15F	[4SA]SST1-18M
[7B1]BKR-81	16M 16F	[4A1]BPR12-13
[7A1]BP127-14	17M 17F	[4A1]BPF15-A
[7A1]BP127-11	18M 18F	[4A1]BPTPB-2M
[7B1]BKR-31	19M 19F	[4A1]BPTC-7
[7B1]BKR-21	20M 20F	[4A1]BPTC-8
[7B1]BKR-321	21M 21F	[4A1]BPTC-10
[7B1]BKR-322	22M 22F	[4A1]BPF16-A
[7A1]BPF3-27	23M 23F	[4SA]SST1-25M
[7A1]BPF3-A	24M 24F	[4SA]SST1-26M
[7F1]XD2-X1	25M 25F	[5A1]BPFUV1-A
[7F1]XD2-X2	26M 26F	[5A1]BPT2-1
[7F3]XTB6-1	27M 27F	[6F3]XTB6-1
[7F3]XTB6-3#12	28M 28F	[6F3]XTB6-3#12
[7F3]XTB6-2	29M 29F	[6F3]XTB6-2
[7F3]XTB6-4#12	30M 30F	[6F3]XTB6-4#12
TTBA-2*RED	31M 31F	[4SA]SST1-31M*RED
TTBA-3*RED	32M 32F	[4SA]SST1-32M*RED
TTBA-8*RED	33M 33F	[6SA]TTBA-3*RED
TTBA-7*WHT	34M 34F	[6SA]TTBA-2*WHT
TTBA-5*RED	35M 35F	[4SA]SST1-35M*RED
TTBA-6*WHT	36M 36F	[4SA]SST1-36M*WHT

PULL-APART SHIPPING SPLIT TERMINAL BLOCKS
BOTTOM WIREWAY

[7SD]		
SST2		
[7B1]BKR-F2+*RED	1M 1F	[6D1]BKR-F2+*RED
[7B1]BKR-F1-*GRA	2M 2F	[6D1]BKR-F1-*GRA
[7B1]TA-NIN+#22*GRN	3M 3F	[6D1]TA-NIN+#22*GRN
[7B1]TA-NIN+#22*WHT	4M 4F	[6D1]TA-NIN+#22*WHT
[7B1]TA-NOUT+#22*RED	5M 5F	[6D1]TA-NOUT+#22*RED
[7B1]TA-NOUT+#22*BLK	6M 6F	[6D1]TA-NOUT+#22*BLK
[7B1]TA-9*RED	7M 7F	[6D1]TA-10*RED
[7B1]TA-11*GRA	8M 8F	[6D1]TA-12*GRA
[7B1]TA-NSHLD#22*SHLD	9M 9F	[6D1]TA-NSHLD#22*SHLD
[7B1]XBA-3*RED72	10M 10F	[4B1]BPT7-3*RED70
[7B1]XBA-1*GRA72	11M 11F	[4B1]BPT7-2*GRA70
[7B1]BPT7-1*RED73	12M 12F	[4B1]XBA-3*RED71
[7B1]BPT7-2*GRA73	13M 13F	[4B1]XBA-1*GRA71
	14M 14F	
	15M 15F	
	16M 16F	

- NOTES:
1. ALL #22 AWG WIRE WITH A COLOR DESIGNATION (RED, BLK, WHT, GRN) IS 2466C 4-CONDUCTOR ALPHA CABLE (OR EQUIVALENT).
2. ALL WIRE DESIGNATIONS INCLUDING A COLOR (GRA, RED) PLUS A ONE OR TWO DIGIT NUMBER INDICATE A TWISTED PAIR. FOR EXAMPLE, GRA70 AND RED70 MAKE UP A SINGLE TWISTED PAIR WIRE.
3. ROUTE ALL SHIELDED CABLE AND TWISTED PAIR WIRE IN BOTTOM WIREWAY.

SECTION [7]

JOB NAME:	JHU/APL SUBS 2 & 3 CONSOLIDATION	EQUIPMENT DESIGNATION:	SUBSTATION A
JOB LOCATION:	LAUREL MD	EQUIPMENT TYPE:	PZ4 SWITCHGEAR
DRAWN BY:	A.JEER	DRAWING TYPE:	WIRING DIAGRAM
ENGR:	S.ADONGO		
DATE:	FEBRUARY 08, 2010	by Schneider Electric	
DRAWING STATUS:	RECORD	DWG#	W27452521-006-07
		PG 4	OF 4
		REV B	

REV	DESCRIPTION	BY	DATE								
-	-	-	-	-	-	-	-	-	-	-	-

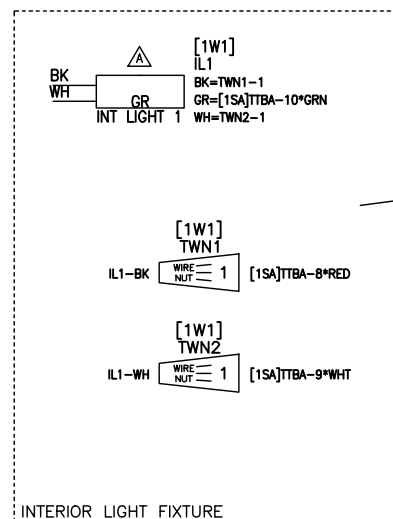

PZ4 UPPER WIREWAY

P/N: 9080GR6 (10)
P/N: 9080GMB8
P/N: 9080MHA10 (2)

[1SA] TTBA	
1	[1A1]BP50-2,[1W1]LWN1-1*RED
2	[1D1]BPDB-N1#12,[2SA]TTBA-2*WHT
3	[1F4]GND-10#12,[1W1]LWN4-1*GRN
4	[1W1]LWN2-1,[4SA]SST1-31F*RED
5	[1W1]LWN3-1,[4SA]SST1-32F*RED
6	[1A1]BP51-2,[1W1]LWN5-1*RED
7	[1D1]BPDB-N1#12,[1W1]LWN6-1*WHT
8	[1W1]TWN1-1,[2SA]TTBA-3*RED
9	[1W1]TWN2-1*WHT
10	[1W1]IL1-GR*GRN

JUMP 2 & 9 [L]*WHT
JUMP 3 & 10 [L]*GRN

aisle ROOF

6 WIRES

WIRE CONDUIT TO PZ4 CONDUIT PLATE

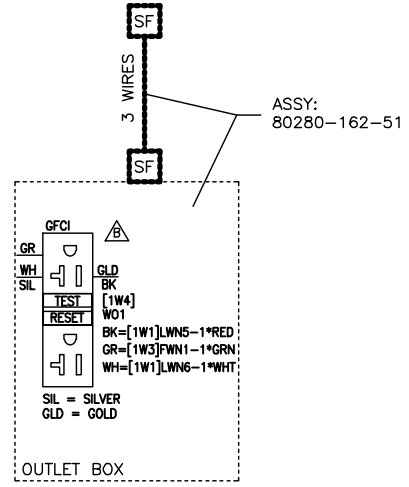
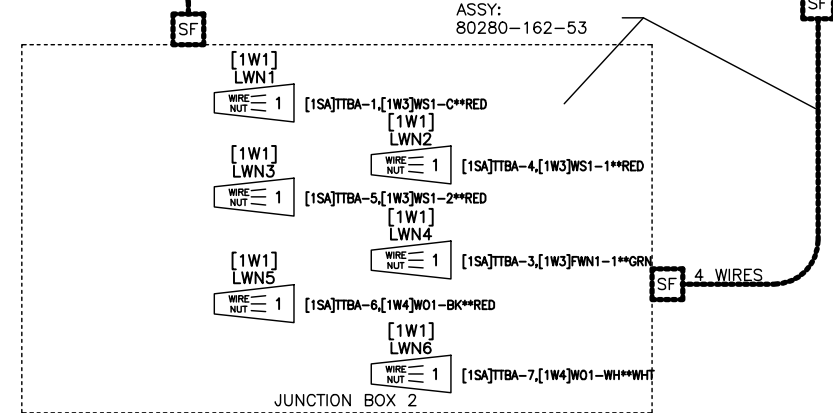
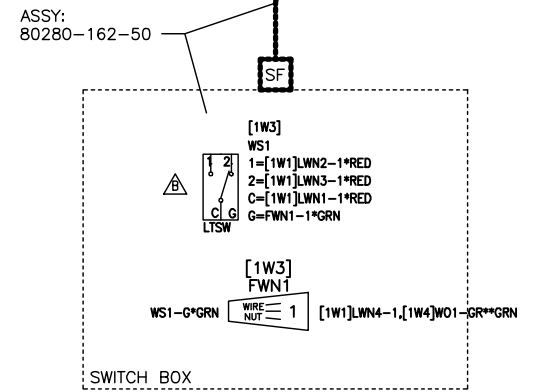

aisle FRONT WALL

aisle LEFT END WALL

LEGEND	NOTE
— INDICATES 1/2" WIRE CONDUIT	⚡ CONNECTION TO GROUND (GR) IS MADE BY RING LUG AND SCREW TO LIGHT FIXTURE HOUSING
SF = STRAIGHT CONDUIT FITTING	⚠ CONNECTION TO DEVICE IS MADE BY RING LUG OR FORK LUG
AF = ANGLE CONDUIT FITTING	

NEMA 3R ENCLOSURE SECTION [1]

JOB NAME:	JHU/APL SUBS 2 & 3 CONSOLIDATION	EQUIPMENT DESIGNATION:	STATION A
JOB LOCATION:	LAUREL MD	EQUIPMENT TYPE:	PZ4 SWITCHGEAR
DRAWN BY:	A.JEER	DRAWING TYPE:	WIRING DIAGRAM
ENGR:	S.ADONGO		
DATE:	FEBRUARY 08, 2010	by Schneider Electric	
DRAWING STATUS:	RECORD	DWG#	W2745251-006-WI

REV	DESCRIPTION	BY	DATE								
-	-	-	-	-	-	-	-	-	-	-	-

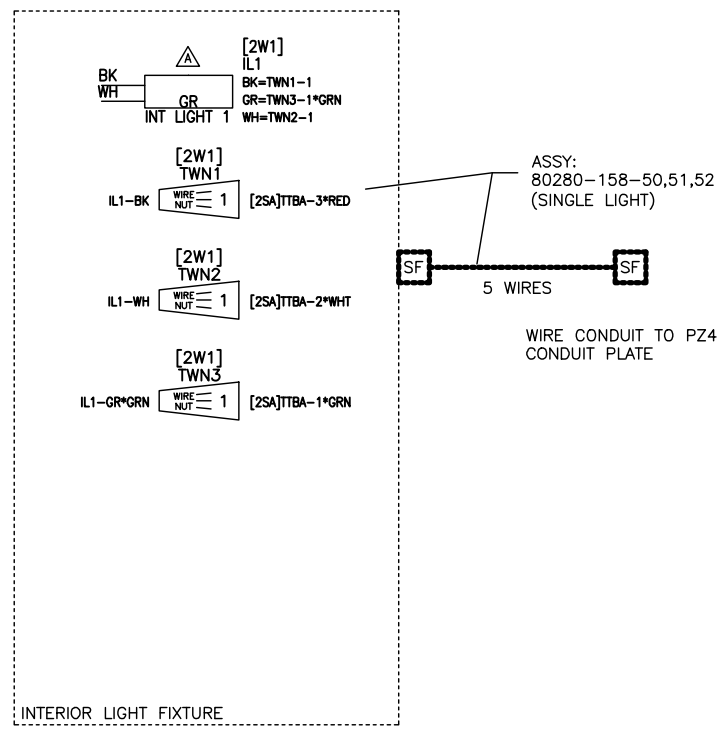

PZ4 UPPER WIREWAY

P/N: 9080GR6 (3)
P/N: 9080M6B
P/N: 9080MHA10 (2)
[2SA]
TTBA

[3SA]TTBA-2*WHT	1	[2F4]GND-1#12,[2W1]TWN3-1*GRN
[3SA]TTBA-3*RED	2	[1SA]TTBA-2,[2W1]TWN2-1**WHT
	3	[1SA]TTBA-8,[2W1]TWN1-1**RED

AISLE ROOF

AISLE FRONT WALL

LEGEND
— INDICATES 1/2" WIRE CONDUIT
SF = STRAIGHT CONDUIT FITTING
AF = ANGLE CONDUIT FITTING

NOTE
⚠ CONNECTION TO GROUND (GR) IS MADE BY RING LUG AND SCREW TO LIGHT FIXTURE HOUSING
⚠ CONNECTION TO DEVICE IS MADE BY RING LUG OR

NEMA 3R ENCLOSURE SECTION [2]

JOB NAME:	JHU/APL SUBS 2 & 3 CONSOLIDATION	EQUIPMENT DESIGNATION:	SUBSTATION A
JOB LOCATION:	LAUREL MD	EQUIPMENT TYPE:	PZ4 SWITCHGEAR
DRAWN BY:	A.JEER	DRAWING TYPE:	WIRING DIAGRAM
ENGR:	S.ADONGO		
DATE:	FEBRUARY 08, 2010	by Schneider Electric	
DRAWING STATUS:	RECORD	DWG#	W27452521-006-WI

REV	DESCRIPTION	BY	DATE								
-	-	-	-	-	-	-	-	-	-	-	-

AISLE FRONT WALL

AISLE ROOF

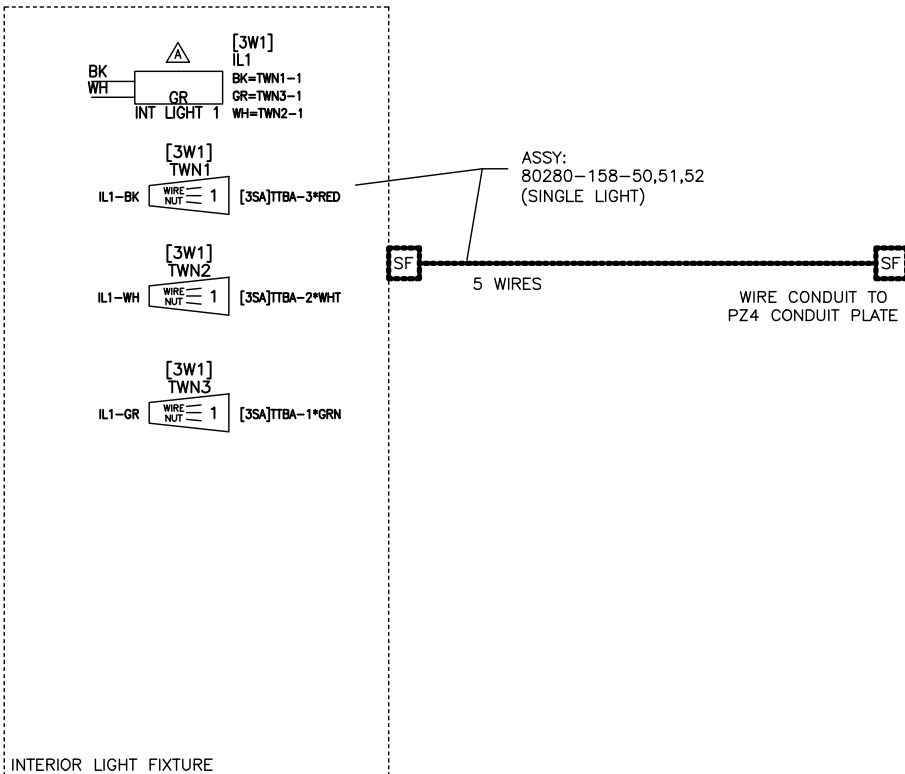

PZ4 UPPER WIREWAY

P/N: 9080GR6 (3)
P/N: 9080M6B
P/N: 9080MHA10 (2)

[3SA]
TTBA

1	[3F4]GND-1#12,[3W1]TWN3-1*GRN
2	[2SA]TTBA-2,[3W1]TWN2-1**WHT
3	[2SA]TTBA-3,[3W1]TWN1-1**RED

[4SA]SST1-34F*WHT
[4SA]SST1-33F*RED

LEGEND

— INDICATES 1/2" WIRE CONDUIT
SF = STRAIGHT CONDUIT FITTING
AF = ANGLE CONDUIT FITTING

NOTE

△ CONNECTION TO GROUND (GR) IS MADE BY RING LUG AND SCREW TO LIGHT FIXTURE HOUSING
△ CONNECTION TO DEVICE IS MADE BY RING LUG OR

NEMA 3R ENCLOSURE SECTION [3]

JOB NAME:	JHU/APL SUBS 2 & 3 CONSOLIDATION	EQUIPMENT DESIGNATION:	SUBSTATION A
JOB LOCATION:	LAUREL MD	EQUIPMENT TYPE:	PZ4 SWITCHGEAR
DRAWN BY:	A.JEER	DRAWING TYPE:	WIRING DIAGRAM
ENGR:	S.ADONGO		
DATE:	FEBRUARY 08, 2010	by Schneider Electric	
DRAWING STATUS:	RECORD	DWG#	W27452521-006-WI

REV	DESCRIPTION	BY	DATE								
-	----	--	---/---/---	-	----	--	---/---/---	-	----	--	---/---/---

AISLE FRONT WALL
 AISLE ROOF
 PZ4 UPPER WIREWAY

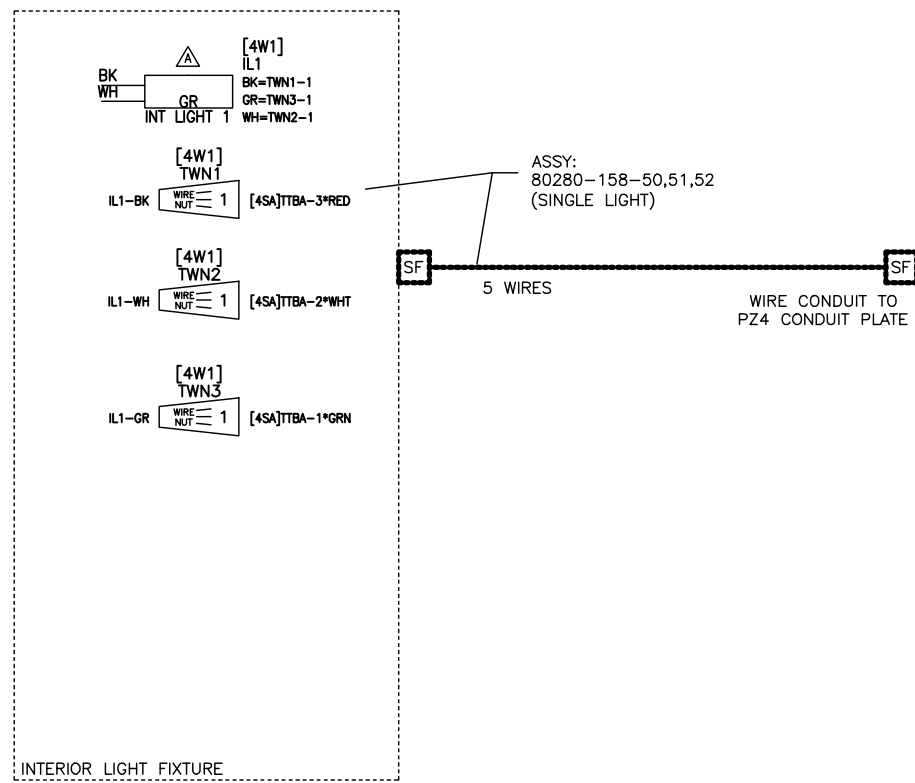

P/N: 9080GR6 (3)
 P/N: 9080M6B
 P/N: 9080MHA10 (2)
 [4SA]
 TTBA

1	[4F4]GND-4#12,[4W1]TWN3-1*GRN
2	[4W1]TWN2-1,[5SA]TTBA-2**WHT
3	[4W1]TWN1-1,[5SA]TTBA-3**RED

SST1-34**WHT
 SST1-33**RED

LEGEND
 — INDICATES 1/2" WIRE CONDUIT
 SF = STRAIGHT CONDUIT FITTING
 AF = ANGLE CONDUIT FITTING

NOTE
 ⚠ CONNECTION TO GROUND (GR) IS MADE BY RING LUG AND SCREW TO LIGHT FIXTURE HOUSING
 ⚠ CONNECTION TO DEVICE IS MADE BY RING LUG OR

NEMA 3R ENCLOSURE SECTION [4]

JOB NAME:	JHU/APL SUBS 2 & 3 CONSOLIDATION	EQUIPMENT DESIGNATION:	SUBSTATION A
JOB LOCATION:	LAUREL MD	EQUIPMENT TYPE:	PZ4 SWITCHGEAR
DRAWN BY:	A.JEER	DRAWING TYPE:	WIRING DIAGRAM
ENGR:	S.ADONGO		
DATE:	FEBRUARY 08, 2010		
DRAWING STATUS:	RECORD	DWG#	W27452521-006-WI

REV	DESCRIPTION	BY	DATE								
-	-	-	-	-	-	-	-	-	-	-	-

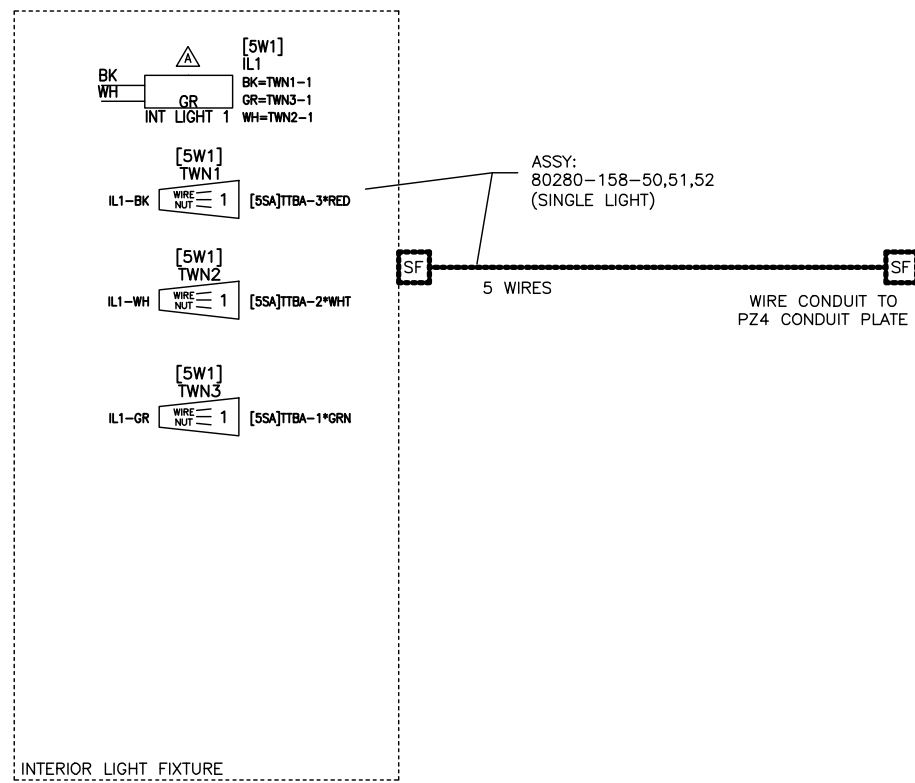

PZ4 UPPER WIREWAY

P/N: 9080GR6 (3)
P/N: 9080M6B
P/N: 9080MHA10 (2)

[5SA] TTBA	
1	[5F4]GND-1#12,[5W1]TWN3-1*GRN
2	[4SA]TTBA-2,[5W1]TWN2-1**WHT
3	[4SA]TTBA-3,[5W1]TWN1-1**RED

AISLE ROOF

AISLE FRONT WALL

LEGEND

— INDICATES 1/2" WIRE CONDUIT
SF = STRAIGHT CONDUIT FITTING
AF = ANGLE CONDUIT FITTING

NOTE

⚠ CONNECTION TO GROUND (GR) IS MADE BY RING LUG AND SCREW TO LIGHT FIXTURE HOUSING
⚠ CONNECTION TO DEVICE IS MADE BY RING LUG OR

NEMA 3R ENCLOSURE SECTION [5]

JOB NAME:	JHU/APL SUBS 2 & 3 CONSOLIDATION	EQUIPMENT DESIGNATION:	SUBSTATION A
JOB LOCATION:	LAUREL MD	EQUIPMENT TYPE:	PZ4 SWITCHGEAR
DRAWN BY:	A.JEER	DRAWING TYPE:	WIRING DIAGRAM
ENGR:	S.ADONGO		
DATE:	FEBRUARY 08, 2010	by Schneider Electric	
DRAWING STATUS:	RECORD	DWG#	W27452521-006-WI

REV	DESCRIPTION	BY	DATE								
-	----	--	--/--/--	-	----	--	--/--/--	-	----	--	--/--/--

AISLE FRONT WALL
 AISLE ROOF
 PZ4 UPPER WIREWAY

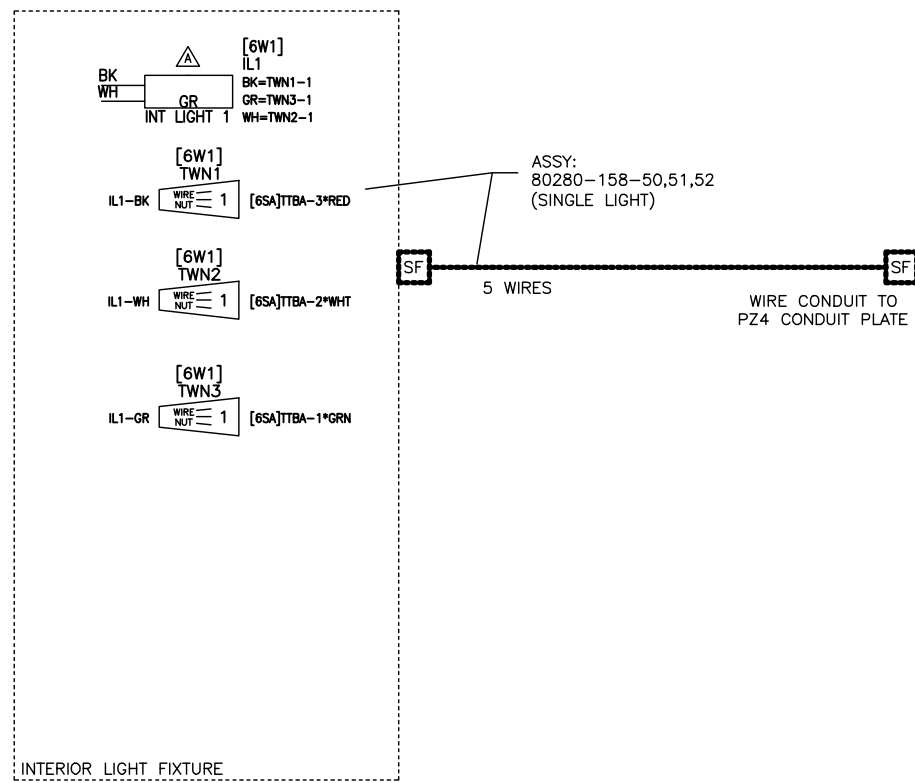

PZ4 UPPER WIREWAY

P/N: 9080GR6 (3)
 P/N: 9080GM6B
 P/N: 9080MHA10 (2)

[6SA]		TTBA	
[6F4]GND-1#12,[6W1]TWN3-1*GRN	1	[7SA]SST1-34F*WHT	2
[5SA]TTBA-2,[6W1]TWN2-1**WHT	2	[7SA]SST1-33F*RED	3
[5SA]TTBA-3,[6W1]TWN1-1**RED	3		

LEGEND
 — INDICATES 1/2" WIRE CONDUIT
 SF = STRAIGHT CONDUIT FITTING
 AF = ANGLE CONDUIT FITTING

NOTE
 ⚠ CONNECTION TO GROUND (GR) IS MADE BY RING LUG AND SCREW TO LIGHT FIXTURE HOUSING
 ⚠ CONNECTION TO DEVICE IS MADE BY RING LUG OR

NEMA 3R ENCLOSURE SECTION [6]

JOB NAME:	JHU/APL SUBS 2 & 3 CONSOLIDATION	EQUIPMENT DESIGNATION:	SUBSTATION A
JOB LOCATION:	LAUREL MD	EQUIPMENT TYPE:	PZ4 SWITCHGEAR
DRAWN BY:	A.JEER	DRAWING TYPE:	WIRING DIAGRAM
ENGR:	S.ADONGO		
DATE:	FEBRUARY 08, 2010		
DRAWING STATUS:	RECORD	DWG#	W27452521-006-WI

REV	DESCRIPTION	BY	DATE						
-	-	-	-	-	-	-	-	-	-

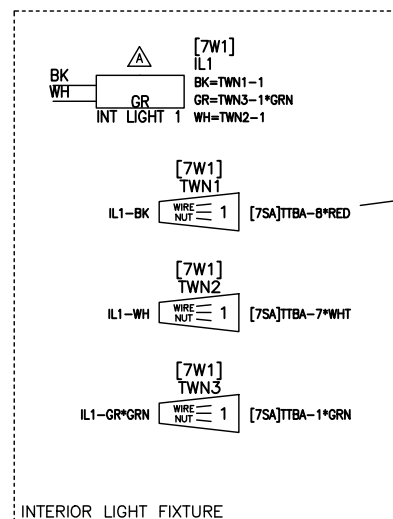

ASSY:
80280-158-52
(SINGLE LIGHT)

PZ4 UPPER WIREWAY

P/N: 9080GR6 (8)
P/N: 9080GM6B
P/N: 9080MHA10 (2)

[7W3]FWN1-1	1	[7F4]GND-5#12,[7W1]TWN3-1*GRN
SST1-31M*RED	2	[7W1]RWN2-1*RED
SST1-32M*RED	3	[7W1]RWN3-1*RED
SST1-35M*RED	4	[7W1]RWN4-1*RED
SST1-36M*WHT	5	[7W1]RWN5-1*WHT
SST1-34M*WHT	6	[7W1]TWN2-1*WHT
SST1-33M*RED	7	[7W1]TWN1-1*RED
	8	[7W1]TWN1-1*RED

JUMP 4 & 8 [L]*RED

aisle ROOF

6 WIRES

WIRE CONDUIT TO PZ4 CONDUIT PLATE

ASSY: 80280-162-50

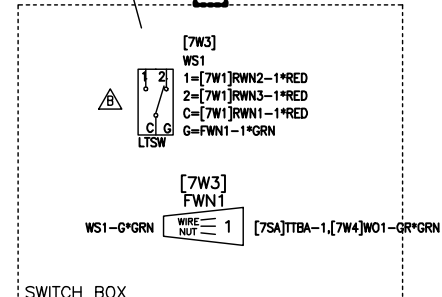

ASSY: 80280-162-53

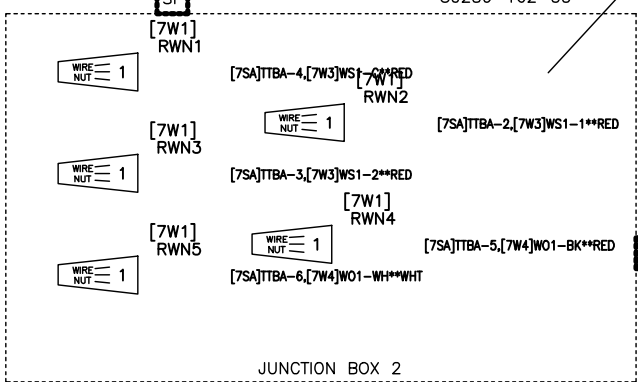

3 WIRES

ASSY: 80280-162-51

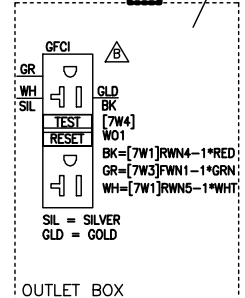

aisle FRONT WALL

aisle LEFT END WALL

LEGEND
 — INDICATES 1/2" WIRE CONDUIT
 SF = STRAIGHT CONDUIT FITTING
 AF = ANGLE CONDUIT FITTING

NOTE
 ⚡ CONNECTION TO GROUND (GR) IS MADE BY RING LUG AND SCREW TO LIGHT FIXTURE HOUSING
 ⚡ CONNECTION TO DEVICE IS MADE BY RING LUG OR FORK LUG

NEMA 3R ENCLOSURE SECTION [7]

JOB NAME:	JHU/APL SUBS 2 & 3 CONSOLIDATION	EQUIPMENT DESIGNATION:	STATION A
JOB LOCATION:	LAUREL MD	EQUIPMENT TYPE:	PZ4 SWITCHGEAR
DRAWN BY:	A.JEER	DRAWING TYPE:	WIRING DIAGRAM
ENGR:	S.ADONGO		
DATE:	FEBRUARY 08, 2010		
DRAWING STATUS:	RECORD	DWG#	W2745251-006-WI

PG7 OF7 REV -

REV	DESCRIPTION	BY	DATE						
-	-	-	-	-	-	-	-	-	-

STANDARD LAYOUT FOR TYPICAL FOUR HIGH SWITCHGEAR/SWITCHBOARD

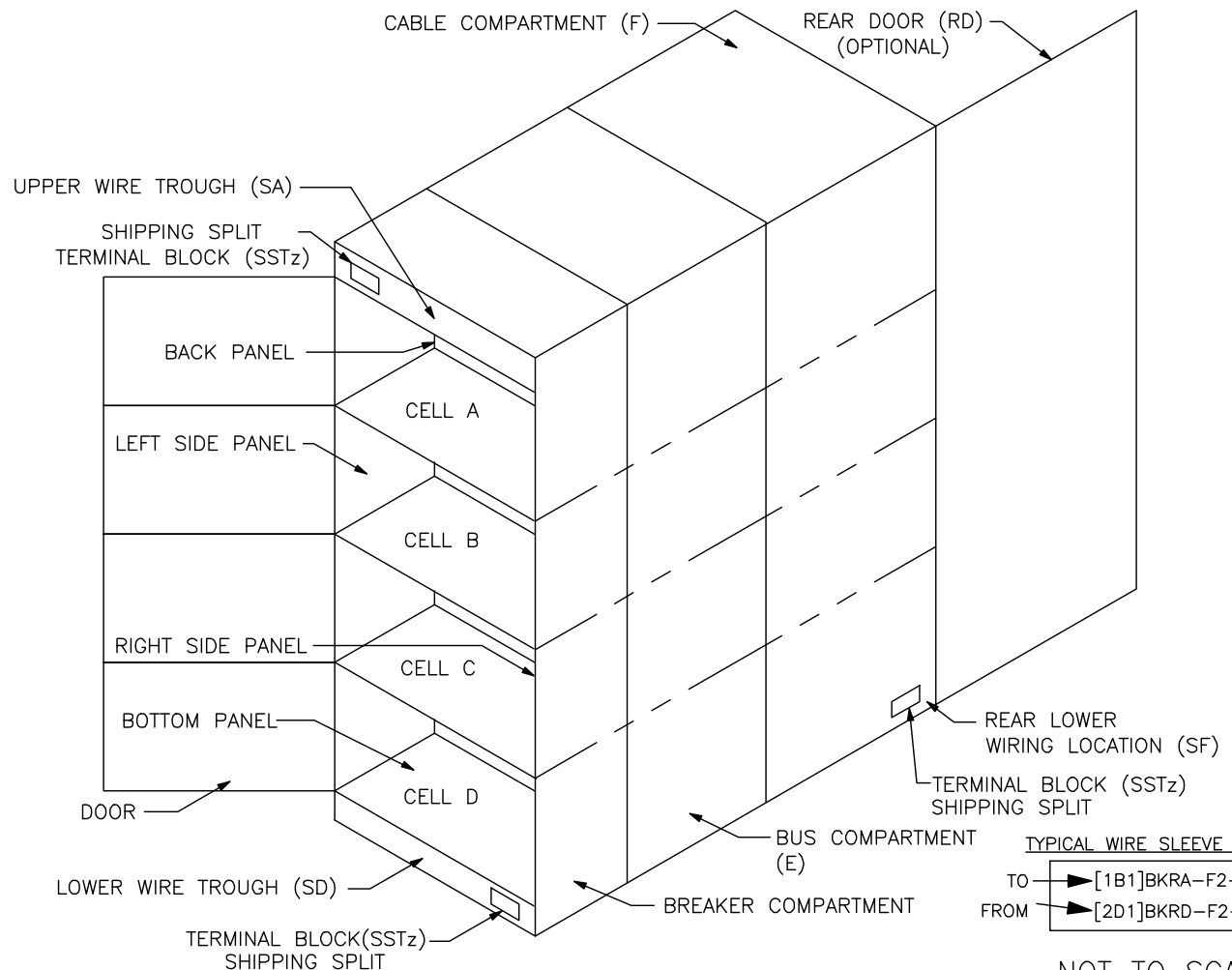

NOT TO SCALE

[DEVICE LOCATOR DESIGNATIONS]
 BPz = ANY DEVICE LOCATED ON COMPARTMENT BACK MOUNTING PANEL.
 BPTz= TERMINAL BLOCK LOCATED ON COMPARTMENT BACK MOUNTING PANEL.
 BKRz= CIRCUIT BREAKER.
 Dz = DEVICES LOCATED ON DOOR.
 Lz = ANY DEVICE LOCATED ON LEFT SIDE PANEL OF A COMPARTMENT.
 LTz = TERMINAL BLOCK LOCATED ON LEFT SIDE PANEL OF A COMPARTMENT.
 Rz = ANY DEVICE LOCATED ON RIGHT SIDE PANEL OF A COMPARTMENT.
 RTz = TERMINAL BLOCK LOCATED ON RIGHT SIDE PANEL OF A COMPARTMENT.
 Tz = ANY DEVICE LOCATED ON TOP PANEL OF A COMPARTMENT.
 TTz = TERMINAL BLOCK LOCATED ON TOP PANEL OF A COMPARTMENT.
 XTz = TERMINAL BLOCK LOCATED ON BOTTOM PANEL OF A COMPARTMENT.
 Xz = ANY DEVICE LOCATED ON BOTTOM PANEL OF A COMPARTMENT.
 JTz = ANY DEVICE LOCATED TOP OF THE ROOF.

[XYZ] SECTION/CELL LOCATION
 COMPARTMENT OR CELL SUBDIVISION
 1-4=EACH COMPARTMENT OR CELL MAY BE SUBDIVIDED.
 SECTION LOCATION = A,B,C,D,E,F,W
 A = TOP CELL
 B = SECOND TO TOP CELL
 C = SECOND TO BOTTOM CELL
 D = BOTTOM CELL
 E = BUS COMPARTMENT
 F = CABLE COMPARTMENT
 W = N3R WALKIN SECTION
 SECTION NUMBER
 WHEN VIEWING LINE UP FROM THE FRONT,
 THE LEFT MOST VERTICAL SECTION IS SECTION 1.

SPECIAL SPECIFIC DEVICE DESIGNATIONS
 SSTz= SHIPPING SPLIT TERMINAL BLOCK.
 STz = CURRENT TRANSFORMER SHORTING TERMINAL BLOCK.
 xHz = THERMOSTATS
 GNDz= SECTION GROUND BUS CONNECTION

[XYZ] SPECIAL SECTION/CELL LOCATION
 SPECIAL LOCATION - SA,SD,SF,RD,J1
 SA = UPPER WIRE TROUGH
 SD = LOWER WIRE TROUGH
 SF = REAR LOWER WIRING LOCATION
 RD = REAR DOOR
 J1 = ROOF
 SECTION NUMBER
 WHEN VIEWING LINE UP FROM THE FRONT,
 THE LEFT MOST VERTICAL SECTION IS SECTION 1.

FROM/TO WIRING INFORMATION

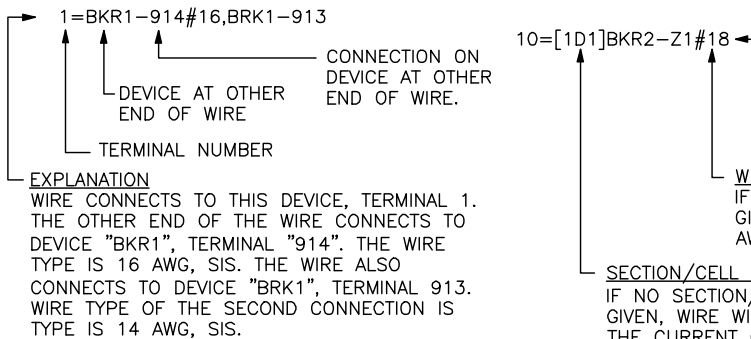

CELL DOOR BREAKER PLACEMENT DESIGNATION

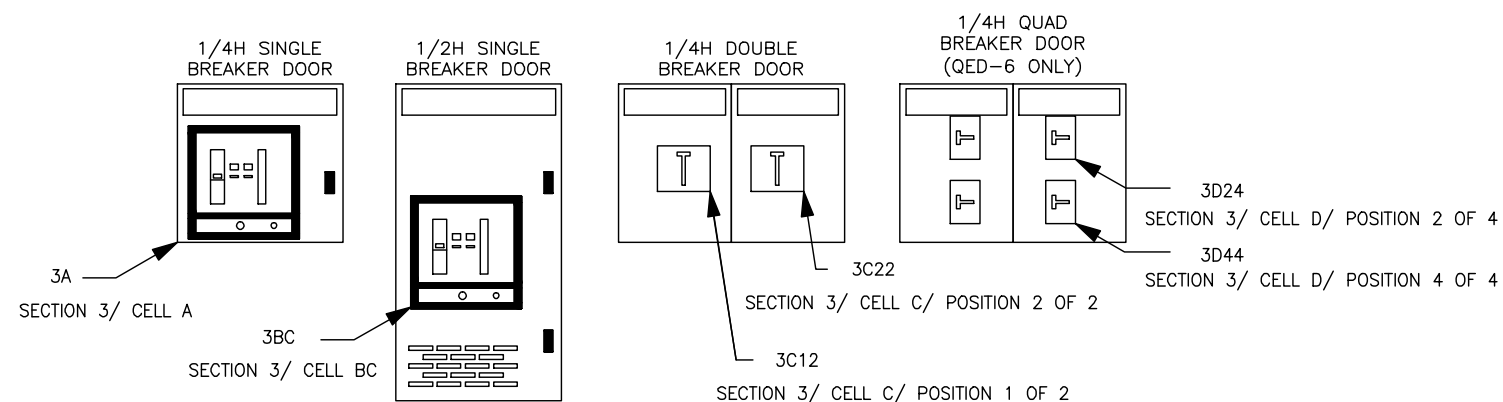

EXPLANATION
 FIRST NUMBER INDICATES SECTION (SEE NOTE 1)
 SECOND LETTER INDICATES CELL (SEE NOTE 1)
 THIRD NUMBER INDICATES BREAKER POSITION WITHIN CELL
 FOURTH NUMBER INDICATES TOTAL NUMBER OF BREAKERS LOCATED WITHIN CELL

NOTE:
 1. CELL DOOR DESIGNATIONS WITH ONLY SECTION AND CELL INDICATION NUMBERS IMPLY A SINGLE BREAKER DESIGNATION.
 2. BREAKER POSITION DESIGNATIONS ARE OREINTED FROM LEFT TO RIGHT, THEN TOP TO BOTTOM.

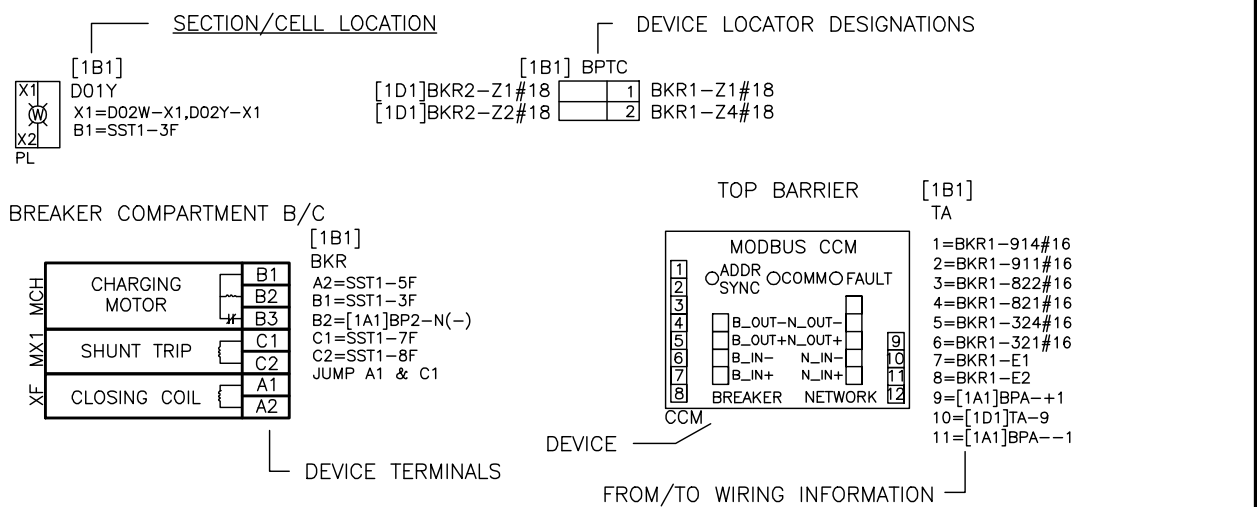

ELEMENTARY & WIRING DIAGRAM LAYOUT INFORMATION

JOB NAME:	JHU/APL SUBS 2 & 3 CONSOLIDATION	EQUIPMENT DESIGNATION:	SUBSTATION A
JOB LOCATION:	LAUREL MD	EQUIPMENT TYPE:	PZ4 SWITCHGEAR
DRAWN BY:	S.KUNDU/A.JEER	DRAWING TYPE:	ISOMETRIC VIEW/ COMPARTMENT DESIGNATION
ENGR:	S.ADONGO		
DATE:	NOVEMBER 11 2009		
DRAWING STATUS:	RECORD	DWG#	I27452521-006-01

REV	DESCRIPTION	BY	DATE								
-	-	-	-	-	-	-	-	-	-	-	-

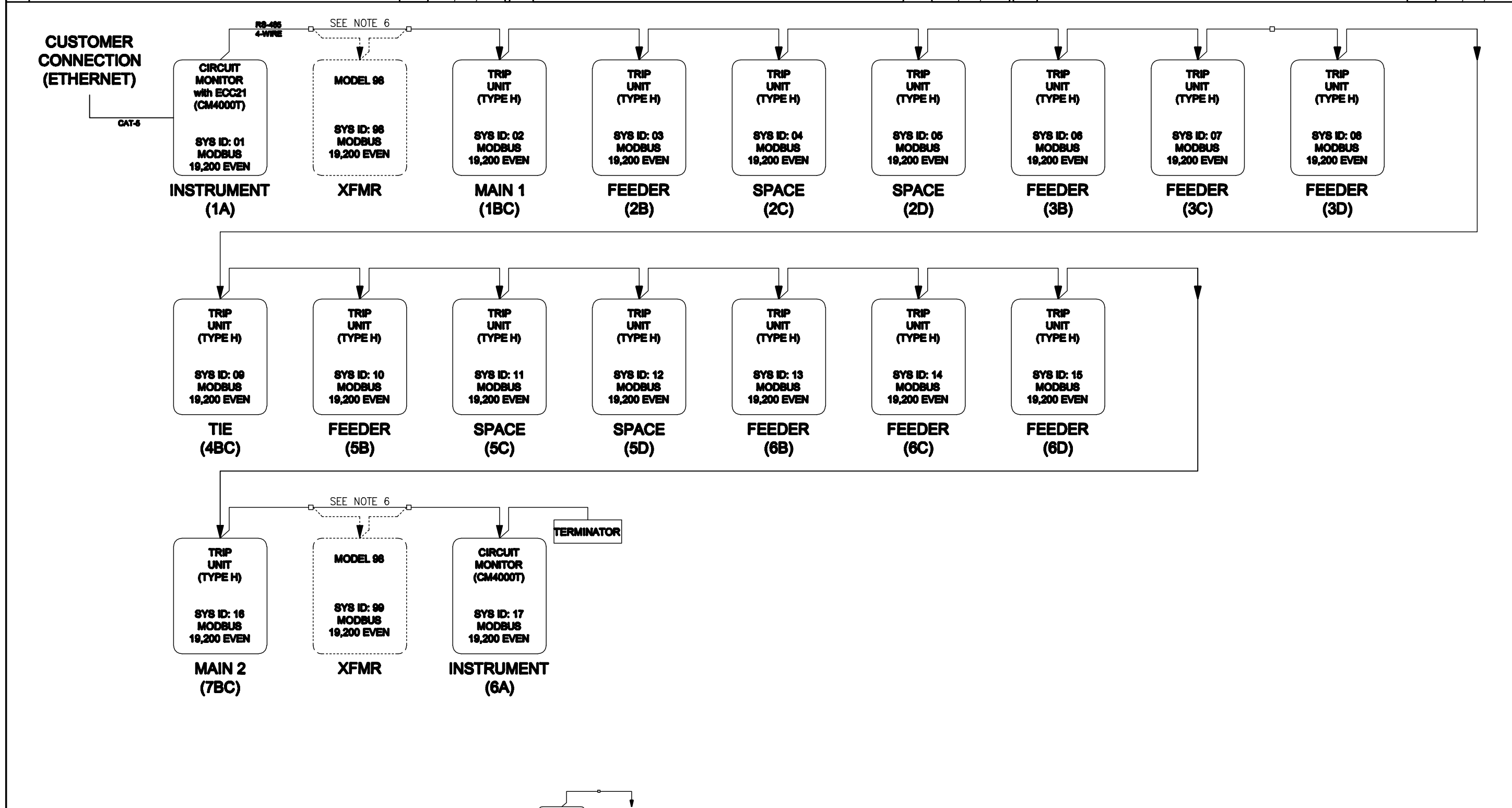

- NOTES:
1. FACTORY TO SET IP ADDRESS TO 10.10.10.10 BEFORE SHIPPING.
 2. CUSTOMER TO INPUT THEIR IP ADDRESS WHEN COMMISSIONING.
 3. ON ADDITIONS TO EXISTING JOBS, MATCH EXISTING BAUD RATE AND PARITY.
 4. FIELD WIRING (MODBUS RS485 USING ALPHA 2466C OR EQUIVALENT)
 5. □ INDICATES TERMINAL BLOCK
 6. REMOVE JUMPERS WHEN WIRING MODEL 98

COMMUNICATION ONE-LINE

JOB NAME:	JHU/APL SUBS 2 & 3 CONSOLIDATION	EQUIPMENT DESIGNATION:	SUBSTATION A
JOB LOCATION:	LAUREL MD	EQUIPMENT TYPE:	PZ4 SWITCHGEAR
DRAWN BY:	S.KUNDU/AJEER	DRAWING TYPE:	COMMUNICATIONS ONE-LINE DIAGRAM
ENGR:	S.ADONGO		
DATE:	NOVEMBER 11 2009		
DRAWING STATUS:	RECORD	DWG#	I27452521-006-02
		PG 1	OF 1
		REV -	

REV	DESCRIPTION	BY	DATE																		
-	----	-	---/---/---	-	----	-	----	-	----	-	----	-	----	-	----	-	----	-	----	-	----

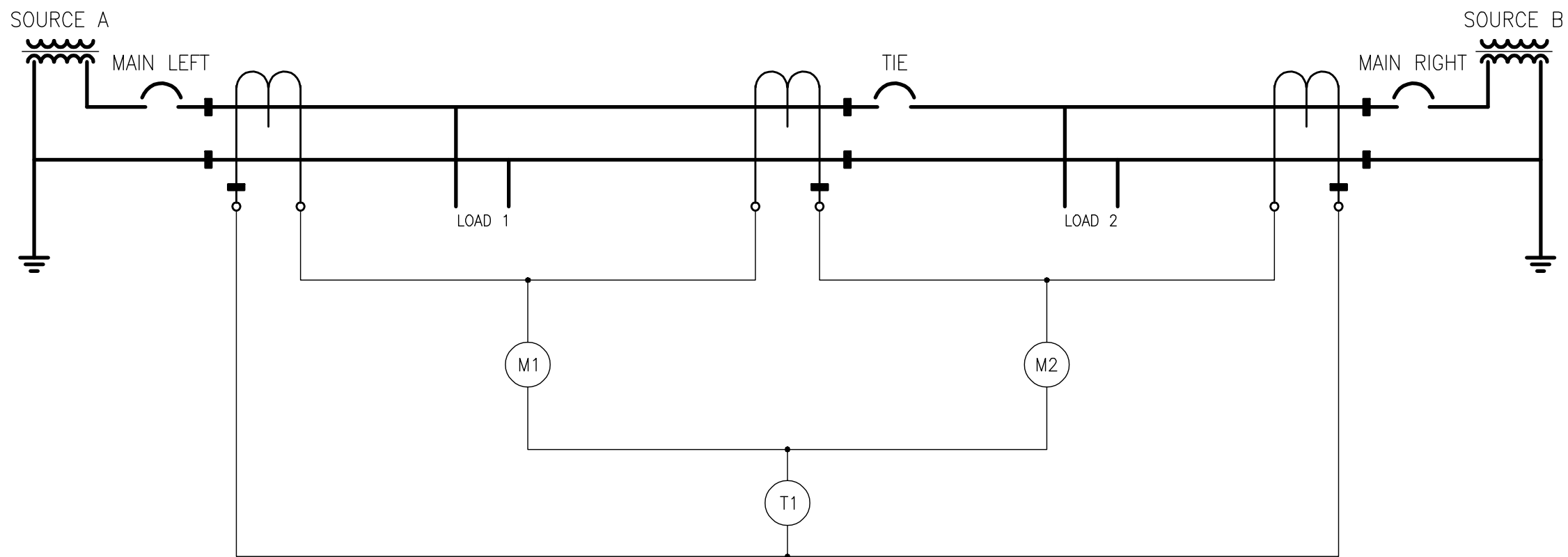

NOTES:

1. NO GROUNDING CONDUCTORS CAN BE PLACED ON THE LOAD SIDE OF THE NEUTRAL SENSORS.
2. PHASE SENSORS MAY BE LOCATED ON THE LINE SIDE OF THE MAIN BREAKER.
3. DETAILS OF THE LOAD (BRANCH) BREAKERS ARE NOT SHOWN. LOADS FED BY MORE THAN ONE BRANCH BREAKER OR ADDITIONAL SOURCES (SUCH AS AUTOMATIC TRANSFER SWITCHES) CAN CREATE PARALLEL CURRENT PATHS THAT WILL DEFEAT THIS GROUND FAULT SYSTEM. ALL DOWNSTREAM AUTOMATIC TRANSFER SWITCHES SHOULD BE 4-POLE, NON-OVERLAPPING SWITCHED NEUTRAL TO PREVENT PARALLEL CURRENT PATHS. THE ADDITION OF DOWNSTREAM PARALLEL NEUTRAL PATHS MAY CAUSE NUISANCE TRIPPING RESULTING FROM THE INTRODUCTION OF CIRCULATING CURRENT THROUGH THE GROUND SYSTEM. SQUARE D IS NOT RESPONSIBLE FOR DAMAGES FROM NUISANCE TRIPPING CAUSED BY DOWNSTREAM PARALLEL PATHS.
4. ALL NEUTRAL TO GROUND CONNECTIONS MUST ONLY BE MADE ON THE SOURCE SIDE OF THE SERVICE ENTRANCE NEUTRAL SENSORS.
5. MDGF SENSOR WINDING POLARITIES AND MOUNTING INSTRUCTIONS MUST BE STRICTLY OBSERVED AND WIRING DIAGRAMS FOLLOWED.
6. DO NOT GROUND THE SECONDARY WINDINGS OF ANY SENSORS.
7. LOAD NEUTRAL CABLES MUST BE CONNECTED TO THE NEUTRAL BUS IN THE PROPER SECTION.
8. MECHANICAL RESETTING OF CIRCUIT BREAKERS AND RESTORATION TO NORMAL SERVICE IS REQUIRED AFTER CIRCUIT BREAKERS HAVE TRIPPED OPEN.
9. GROUND FAULT INTERFACE MODULE TO CIRCUIT BREAKER CONNECTIONS REQUIRE A MINIMUM OF 18AWG SHIELDED CABLE OR TWISTED PAIR WITH A MAXIMUM CABLE LENGTH OF 32 FEET. GROUND FAULT INTERFACE MODULE TO CURRENT SENSOR CONNECTIONS REQUIRE A MINIMUM OF 14AWG SHIELDED CABLE OR TWISTED PAIR WITH A MAXIMUM CABLE LENGTH OF 500 FEET.
10. REFER TO 80043-703-01 FOR TEST PROCEDURE INSTRUCTIONS.
11. DO NOT REMOVE THE FACTORY INSTALLED JUMPERS FROM BETWEEN TERMINALS T1 AND T2. FOR ZSI OPTION(S), THE APPROPRIATE Z3, Z4 AND Z5 JUMPER(S) WILL BE REMOVED.
12. VERIFY THE FACTORY INSTALLED JUMPER BETWEEN TERMINALS 13 AND 14 ON THE GROUND FAULT INTERFACE MODULE, REMOVE ONLY IF USING AN EXTERNAL TRIM RESISTOR.

SEQUENCE OF OPERATION

THIS "RELAYED" TIE GROUND FAULT PROTECTION SYSTEM IS A DIFFERENTIAL SYSTEM FOR USE IN A TWO SOURCE SYSTEM WHERE BOTH OF THE UTILITY TRANSFORMERS OR STATION SERVICE GENERATORS HAVE GROUND "Xo" TERMINALS. THE GROUND FAULT SENSORS (CURRENT TRANSFORMERS) ARE DIFFERENTIALLY CONNECTED TO ENSURE THAT THE SOLID STATE TRIP BREAKERS CAN DIFFERENTIATE BETWEEN CURRENTS AND GROUND FAULT CURRENTS. IF THE SUMMATION OF PHASE CURRENTS FLOWING THROUGH THE SENSORS EXCEED THE TIME AND CURRENT SETTINGS OF THE CIRCUIT BREAKERS, THEN THE SPECIFIED CIRCUIT BREAKER WILL TRIP OPEN.

SELECTIVITY:

DURING A GROUND FAULT CONDITION, THIS SYSTEM DETERMINES THE FAULT'S LOCATION AND TRIPS ALL BREAKERS THAT COULD DELIVER POWER ON A CONTINUING BASIS TO THE FAULTED PORTION OF THE POWER SYSTEM.

FOR EXAMPLE, IF THERE IS A FAULT CONDITION ON LOAD 1 BUS, THEN ONLY BREAKERS M1 & T1 WILL BE TRIPPED BY THE GROUND FAULT SYSTEM. THE GROUND FAULT SYSTEM WILL NOT TRIP BREAKER M2, THEREBY MAINTAINING POWER ON LOAD 2 BUS.

MODIFIED DIFFERENTIAL GROUND FAULT TOPOLOGY

JOB NAME:	JHU/APL SUBS 2 & 3 CONSOLIDATION	EQUIPMENT DESIGNATION:	SUBSTATION A
JOB LOCATION:	LAUREL MD	EQUIPMENT TYPE:	PZ4 SWITCHGEAR
DRAWN BY:	S.KUNDU/AJEER	DRAWING TYPE:	GROUNDFAULT TOPOLOGY
ENGR:	S.ADONGO		
DATE:	NOVEMBER 11 2009	<small>by Schneider Electric</small>	
DRAWING STATUS:	RECORD	DWG#	127452521-006-03
		PG1	OF1
		REV	-

REV	DESCRIPTION	BY	DATE						
-	-	-	-	-	-	-	-	-	-

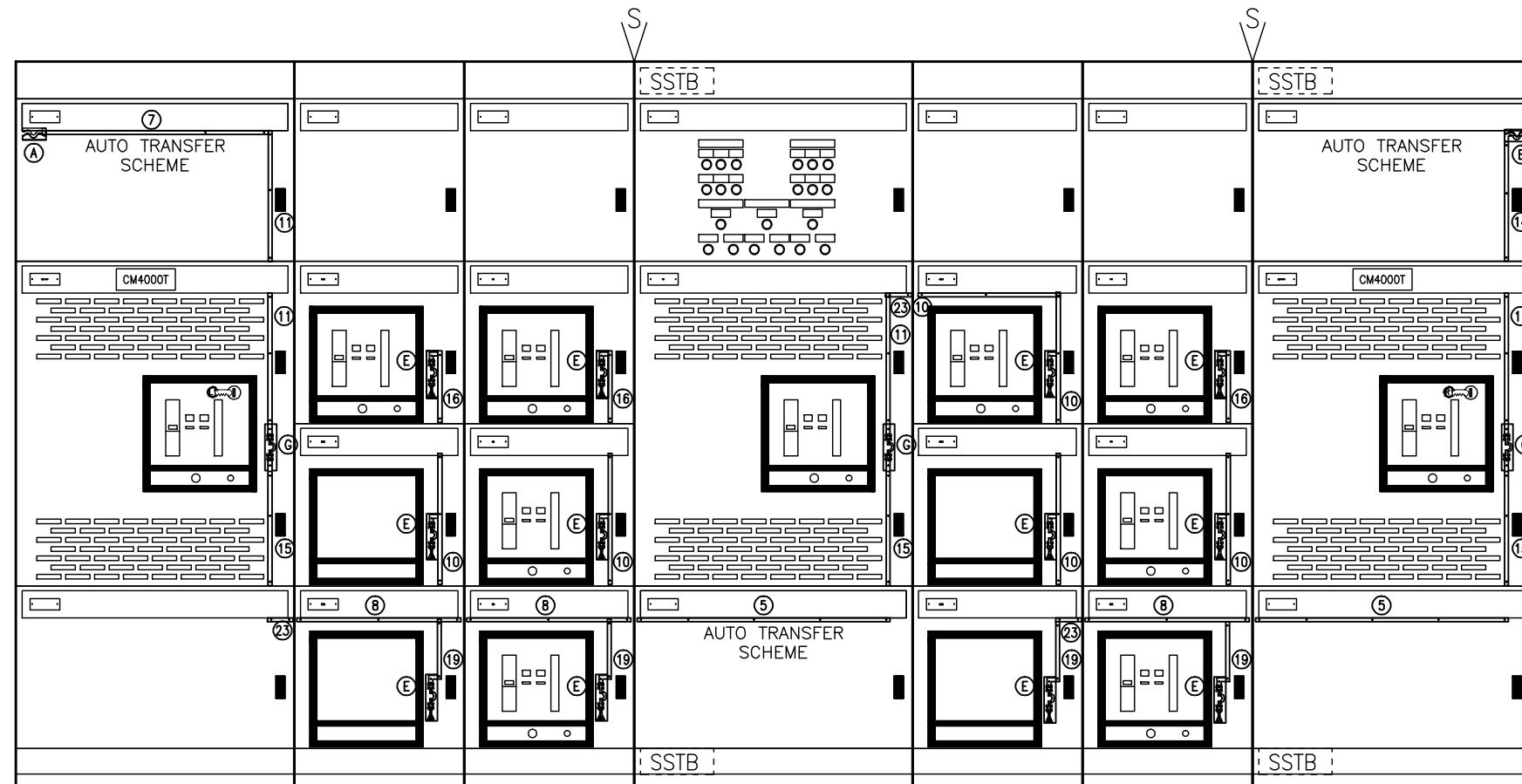

MIMIC BUS PART NUMBERS

MB_A_BG_XFMRLFT	1	MB_CC_BG_24"	0	MB_13_BG_15-7/8"	0
MB_B_BG_XFMRRHT	1	MB_26_BG_1-5/8"	0	MB_12_BG_16-1/2"	0
MB_C_BG_CBL	0	MB_25_BG_2"	0	MB_11_BG_17"	4
MB_D_BG_BSWY	0	MB_24_BG_2-7/8"	0	MB_10_BG_18-3/8"	5
MB_E_BG_FDR_CBL	12	MB_23_BG_3-3/8"	3	MB_9_BG_21"	0
MB_F_BG_FDRBSWY	0	MB_22_BG_4"	0	MB_8_BG_21-1/4"	0
MB_G_BG_MAIN	3	MB_21_BG_4-7/8"	0	MB_7_BG_29-1/4"	1
MB_H_BG_MNBSBTM	0	MB_20_BG_7-1/8"	0	MB_6_BG_31-3/4"	0
MB_I_BG_MNCBBTM	0	MB_19_BG_7-5/8"	4	MB_5_BG_32-3/4"	2
MB_J_BG_MNCBTOP	0	MB_18_BG_7-7/8"	0	MB_4_BG_35-1/4"	1
MB_K_BG_MNBSTOP	0	MB_17_BG_8-3/8"	0	MB_3_BG_36-1/2"	0
MB_L_BG_FDCBSTOP	0	MB_16_BG_9-1/4"	3	MB_2_BG_37-1/2"	0
MB_M_BG_FDBSTOP	0	MB_15_BG_14-3/4"	3	MB_1_BG_38"	0
MB_N_BG_STAT_SW	0	MB_14_BG_15-1/2"	1		

DUAL DIMENSIONS: INCHES
MILLIMETERS

MIMIC BUS

JOB NAME:	JHU/APL SUBS 2 & 3 CONSOLIDATION	EQUIPMENT DESIGNATION:	SUBSTATION A
JOB LOCATION:	LAUREL MD	EQUIPMENT TYPE:	PZ4 SWITCHGEAR
DRAWN BY:	S.KUNDU/A.JEER	DRAWING TYPE:	MIMIC BUS
ENGR:	S.ADONGO		
DATE:	NOVEMBER 11 2009		
DRAWING STATUS:	RECORD	DWG#	N27452521-006-01
		PG 1	OF 2
		REV	-

REV	DESCRIPTION	BY	DATE	-	----	--	--/--/--	-	----	--	--/--/--
-	----	--	--/--/--	-	----	--	--/--/--	-	----	--	--/--/--

○ 27/47 RELAY ○

Quantity = 2
P/N: 80291-034-01

- NOTES:
1. ENGRAVED NAMEPLATES SHALL BE WHITE BACKGROUND WITH BLACK LETTERS.
 2. REFERENCE BREAKER TABLE FOR BREAKER DESIGNATION NAMEPLATE REQUIREMENTS.
 3. REFERENCE PLC DOOR DETAIL DRAWING FOR PLC CONTROLS NAMEPLATE REQUIREMENTS.

NAMEPLATES

JOB NAME:	JHU/APL SUBS 2 & 3 CONSOLIDATION	EQUIPMENT DESIGNATION:	SUBSTATION A
JOB LOCATION:	LAUREL MD	EQUIPMENT TYPE:	PZ4 SWITCHGEAR
DRAWN BY:	S.KUNDU/AJEER	DRAWING TYPE:	NAMEPLATE
ENGR:	S.ADONGO		
DATE:	NOVEMBER 11 2009	<small>by Schneider Electric</small>	
DRAWING STATUS:	RECORD	DWG#	N27452521-006-01
		PG2	OF2
		REV	-